



FY2025 E-Rate Form 471 Category 1 Workshop

Lorrie Germann, State E-Rate Coordinator

The background features a collage of light blue icons representing various digital and educational concepts, such as a laptop, a smartphone, a tablet, a speech bubble, a gear, and a document. Overlaid on this are several stylized illustrations of hands holding different types of electronic devices. Each device's screen displays the text 'E-Rate' in blue, accompanied by a blue Wi-Fi signal icon. The devices include a laptop, a tablet, a smartphone, and a feature phone.

Thanks for joining us, we'll get started at 9:00

**For a copy of today's handout, go to
<https://www.ohio-k12.help/erate/e-rate-resources/>**

FY2025 E-Rate Form 471 Category 1 Workshop

Lorrie Germann, State E-Rate Coordinator

Training Agenda

- Filing Basics – Slide 4
- Accessing the EPC Portal – Slide 10
- Entering Contracts – Slide 14
- Filing the FCC Form 471
 - New Contract Funding Request – Slide 29
 - Continuing Contract (Copy FRN) – Slide 69
 - Off Premises – Slide 77
 - Completing (Submitting) Form 471 – Slide 92
- Next Steps – Slide 99

Filing Basics

Purpose of Form 471

The FCC Form 471

- is filed to request discounts on eligible services.
- **must be filed every year.**
- must reference services that were competitively bid with an FCC Form 470 for at least 28 days, or after a request for proposal (RFP) is made publicly available, whichever is later. (Verify **Allowable Contract Date** posted on Form 470)
- may reference an FCC Form 470 posted in a prior funding year where such a form resulted in a multi-year contract.
- must be filed **after** executing contracts for contracted services, if applicable, or selecting your service provider for tariffed or month-to-month services.

When to File FCC Form 471

- The FCC Form 471 must be filed during a specific application window **each year**.
- All materials associated with the FCC Form 471 must be filed by 11:59 PM ET on or before the last day of the FCC Form 471 application filing window for the request to be considered as inside the window.
 - **Form 471 Filing window:**
 - Opened – **January 15th, 2025** (Noon EST)
 - Closes – **March 26th, 2025** (11:59 pm EDT)
 - **Last date to file a Form 470 – February 26th, 2025**
(11:59 pm EST)

Filing FCC Form 471

- You must complete and submit the FCC Form 471 by filing the form online in EPC.
- You may file more than one FCC Form 471
 - **Note:** you must file separate applications for:
 - **Category One** (Data Transmission and/or Internet Access)
 - **The new Category One (Off-Premises), which includes both School Bus Wi-Fi and hotspots for students or library patrons**
 - **Category Two** (Internal Connections, MIBS, and/or BMIC)
- You may have multiple funding requests on a single Form 471 application.

Prerequisites

- **Entity Profile**

- The values in your applicant entity’s profile had to be updated by Jan. 9th, the close of the Admin Window. If you find that a correction or change is needed, you may note the information on the Form 471 in the narrative of each funding request and make a RAL correction.
- For FY2025, we may use the October 2024 version of the MR-81 (or most current data if you choose).
 - If you participate in CEP, there is a **“CEP Only MR-81 for Base Years 2021 – 2024”** document on my website now.
- If your counts are different from the counts listed in the MR-81, you will be asked how you determined the information. Be sure to document how you arrived at your total numbers.

- **Contracts**

- Before you begin your application, upload contracts that you will be associating with Funding Request Numbers (FRNs) in your entity’s profile, if not already in EPC. **This includes contract addendums.**

CEP Only MR-81

<https://education.ohio.gov/Topics/Student-Supports/Food-and-Nutrition/Resources-and-Tools-for-Food-and-Nutrition/Data-for-Free-and-Reduced-Price-Meal-Eligibility>

Sponsor Name	Site ID	Site Name	Base Year	Enrolled Students	CEP Identified % (Number to use in EPC if school participates in CEP. The 1.6 factor will be applied to calculate the NLSP %)
A+ Arts Academy	30000556	A+ Arts Academy Maybury Campus	2023	169	53.85%
A+ Arts Academy	00000556	A+ Arts Academy Middle	2023	425	61.65%
A+ Children's Academy	00013232	A+ Children's Academy	2024	83	72.29%
Academy for Urban Scholars Youngstown	00013249	Academy for Urban Scholars Youngstown	2024	106	89.62%
Academy for Urban Scholars Youngstown	20013249	Academy for Urban Scholars Youngstown-East Boardman Annex	2024	268	83.96%
Academy of Educational Excellence	00013195	Academy of Educational Excellence	2023	112	58.04%
Adams County/Ohio Valley	00033936	North Adams Elementary School	2024	648	51.39%
Adams County/Ohio Valley	00033944	North Adams High School	2024	415	42.65%
Adams County/Ohio Valley	00070425	Ohio Valley Career & Technical Center	2024	325	53.23%

The **CEP Only MR-81 for Base Years 2021 – 2024** is located at <https://www.ohio-k12.help/e-rate-support/resource-library/>.

At the top of the document is the URL where the data is located on DEW's (f.k.a. ODE) website. USAC now wants this during the application review. If asked for validation of your information, you can provide the MR-81, indicating which row/s your data is listed in. If they insist on a validation letter, I will provide that for you.

Accessing the EPC Portal

USAC's One Portal

Log into One Portal to access the E-Rate Productivity Center (EPC) To access, go to <https://www.usac.org/e-rate/> and click on “Sign In” and then “Continue”.

The image shows two screenshots from the USAC website. The top screenshot is the main website header with the 'Sign In' button highlighted in a red box. The bottom screenshot is the 'E-Rate Productivity Center (EPC)' dashboard, with a red box highlighting the text: 'E-Rate Productivity Center (EPC) - E-Rate Program participants use the E-Rate Productivity Center to manage program processes, receive notifications and to contact customer service. E-Rate Invoices (FCC Form 472/BEAR and FCC Form 474/SPI, EPSI) for FY 2016 or later and all FCC Form 473/SPACs can now be submitted in the EPC. For more information on the legacy system consolidation, please visit our website or contact the Customer Service Center at (888) 203-8100.'

The image shows the USAC login form. It includes the USAC logo, a 'Sign In' button, and a search bar. Below the search bar are navigation links: About, E-Rate, Rural Health Care, Lifeline, High Cost, and Service Providers. The main content area is titled 'E-Rate' and contains the text: 'Ensuring that so across the U.S. information and the internet'. The login form itself has fields for 'Username' and 'Password', a 'Forgot password?' link, and a 'Sign In' button. Below the form is a disclaimer: 'You are accessing a portal to Universal Service Administrative Company (USAC) systems used to administer participation in the federal Universal Service programs in compliance with 47 C.F.R. Part 54. Access to the systems is provided solely to USAC-authorized users for USAC-authorized business purposes. By logging in, you represent that you are an authorized user. Use of this system indicates acceptance of the terms and conditions governing the USAC systems. USAC monitors user access and content for compliance with applicable laws and policies. Use of the system may be recorded, read, searched, copied and/or captured and is also subject to audit. Unauthorized use or misuse of this system is strictly prohibited and subject to disciplinary and/or legal action.' There is a checkbox for 'Click the box to accept' and a 'Sign In' button. At the bottom, there is a link: 'Don't have an account? Create an account'.

Landing Page View

Make sure all your entities are listed.* The District's BEN will be listed first.

If you updated your school's enrollment and NLSP/CEP data by Jan. 9th, you can verify your FY2025 discount rate and C2 Budget.

Click on the name of your district to open the Organization Details page.

News Tasks (4) Records Reports Actions

My Applicant Landing Page

Training
Universal Service Administrative Co.

Welcome, School District 18!

Pending Inquiries

Type: -- Select a Type -- Application/Request: -- Enter an Application/Request ID or Nickname --
Funding Year: -- Select a Funding Year --

APPLY FILTERS CLEAR FILTERS

Pending COMAD Inquiries are not included.

Application/Request Number	Type	Nickname	Inquiry Name	Outreach Type	Date Sent	Due Date	Extn.	Status
No items available								

Notifications

Notification Type: Please select a value Status: All
Funding Year: -- Select a Funding Year -- Generated Not Generated

Notification	Description	Issued Date	Generated By	Generated On
No items available				

My Entities

Entity	Entity Number	City	State	Zip Code
School District 18	170	Springfield	OH	45501
School District 18 NIF	171	Springfield	OH	45501
School District 18 School A	172	Springfield	OH	45502
School District 18 School B	173	Springfield	OH	45501

*If there is an entity missing in the list, contact USAC to request an entity number. However, with the close of the Admin Window, the entity will not be listed in EPC until after the close of the Form 471 Window.

Seeing The District Discount %

Click on “Discount Rate”.

Records / Applicant Entities

#10426 - School District 10997

CREATE A NEW USER | ADD OR REMOVE EXISTING USERS | MANAGE USER PERMISSIONS | ...

Summary | Customer Service | Modifications | Additional Information | **Discount Rate** | Category Two Budget | Contracts | FCC Forms | FRN Appeals | News | Related Actions

Organization Details

Name School District 10997 Applicant Type School District
Entity Number 10426 Status Active
FCC Registration Number 0123456789

Discount rates for Cat 1 and Cat 2 are listed.

Click on “Show Entities” to see a breakdown of each school.

Requested Discount Rate - School District 10997 (BEN: 10426) - FY2024

More than 50 percent of your individual schools must be rural for the school district to be considered rural. (Swing spaces are not considered.)

This discount rate has not been approved for the current year

School District Full-time Enrollment	School District NSLP Count	School District NSLP Percent	School District Urban/Rural Status	Category One Discount Rate	Category Two Discount Rate
1306	1109	85%	Rural	90%	85%

SHOW ENTITIES

HIDE ENTITIES

Entity Details

Organization	BEN	Total Number Of Students Enrolled In School	Total Number Of Students in School Eligible For NSLP	Urban/Rural Status	Alternative Discount
School 2 In District 10997	6911	374	374	Rural	None
School 1 In District 10997	6913	512	467	Rural	None
School 3 In District 10997	6912	420	268	Rural	None

Entering Contracts

Manage Contracts

My Landing Page

Universal Service Administrative Co.

Welcome, School District 18!

Notifications

Notification Type: Please select a value
Funding Year: -- Select a Funding Year --

Status: All
 Generated
 Not Generated

Notification	Description	Issued Date	Generated By
No items available			

My Entities

Entity	Entity Number	City	State
School District 18	170	Springfield	OH
School District 18 NIF	171	Springfield	OH

When requesting a contracted service, you will be required to associate contracts with each FRN. It is recommended (and easier) that you complete this before you begin Form 471.

- **Remember, this may be a formal contract, a copy of a signed/dated hardware quote, or an addendum if changes in service are allowed.**

From your Landing Page, click on your organization (Billed Entity) from the “My Entities” section to display the organization dashboard.

But First, Bid Evaluations!

Factor	Points Available	Vendor 1	Vendor 2	Vendor 3
Price of the ELIGIBLE products and services	50	20	50	40
Prior experience w/vendor	20	20	0	20
Pricing includes basic firewall service	15	0	0	15
Flexible Invoicing: FCC Forms 472 or 474	10	0	10	10
Local or in-state vendor	5	5	0	5
TOTAL	100	45	60	90

Based on the above bid matrix criteria, we have chosen **Vendor 3** as the service provider for our **bandwidth and Internet Access**.

Name: _____

Signature: _____

Date: _____

- **Remember!! Before you award a contract, be sure to construct a bid evaluation!**
- Evaluate your bids with your bid factors listed and assigned points.
- Price must have the highest number of points
- If a vendor was disqualified, they would not be included in the bid matrix table but give an explanation as to why they were disqualified.
- Based on this example, Vendor 3 wins because they received the most points.

For a copy of a Category 1 and Category 2 bid matrix and acceptance letter, go to <https://www.ohio-k12.help/erate/e-rate-resources/>

Manage Contracts

News Tasks (14) Records Reports Actions

Records / Applicant Entities
#10426 - School District 10997

CREATE A NEW USER ADD OR REMOVE EXISTING USERS MANAGE USE

Summary Customer Service Modifications Additional Information Discount Rate Category Two Budget **Contracts** FCC Forms FRN Appeals News Related Actions

Organization Details
Name School District 10997 Applicant Type School District

Entity Records / Applicant Entities
FCC Re #10426 - School District 10997

Contact Summary Customer Service Modifications Additional Information Discount Rate Category Two Budget **Contracts** FCC Forms FRN Appeals News Related Actions

Physica

Submitted Contracts

Contract ID	Contract Number	Contract Nickname	Award Date	
6914		FY2021-FY2025 Bandwidth	12/1/2020	View
6913		BMIC	5/26/2020	View
6821		Test1234321	3/11/2020	View

Click on “Contracts”, and then “Manage Contracts” to add new contracts. To see previously uploaded contracts, click on “View”. **Note:** Once a contract has been added, you cannot edit the information or delete it. If a mistake is found, you will have to add the contract again and reenter the accompanying information.

Manage Contracts – Add New Contract

Manage Contracts

Contracts - School District 10997 (BEN: 10426)

Use the dropdown to select the type of contract you would like to edit or remove. Click the Add a New Contract button at any time to create a new contract for your organization.

Contract Type

My Contract Drafts

The grid below contains all of your draft contracts created for this organization.

- To edit a draft contract, select 1 contract from the grid and click the Edit button at the bottom of the form.
- To delete a draft contract, select up to 5 contracts from the grid and click the Delete button at the bottom of the form.

<input type="checkbox"/>	Contract ID	Contract Number	Contract Nickname	Created	Last Modified
<input type="checkbox"/>	4200	N/A	Test 2 ISP Service	2/27/2017 4:57 PM EST	2/27/2017 4:57 PM EST

Begin by clicking on “Add New Contract”.

Enter a nickname and contract number if known, click on “Save & Continue”.

Note: if you need to stop before completing, click on “Save & Close”.

Create Contract

School District 10997 (BEN: 10426) - My Provider - 5 Year Bandwidth/IA Contract - Contract ID

Contract Information Establishing FCC Form 470 Service Provider Contract Dates Pricing Confidentiality Confirmation

Here you will enter preliminary information about this contract, as well as your account number, if you know it.

Contract Information

Enter a nickname to easily identify this contract *

Contract Number

Manage Contracts – Create Contract

Breadcrumbs are provided to show progress.

Create Contract

School District 10997 (BEN: 10426) - My Provider - 5 Year Bandwidth/IA Contract - Contract ID #7503

Contract Information Establishing FCC Form 470 Service Provider Contract Dates Pricing Confidentiality Confirmation

Here you will have the option to upload contract documents, including a description of each document.

Contract Information

Contract ID #7503

Would you like to upload a copy of your contract?

YES ✓ NO

Contract Document Upload

Please upload and describe each document related to your contract.

My Provider Bandwidth Contract
DOCX - 13.95 KB

UPLOAD Drop file here

Describe this contract document.

Describe this contract document.

BACK CANCEL SAVE & CLOSE SAVE & CONTINUE

To upload a copy of the contract, choose “Yes” and upload the file. Enter a description of the document if you choose. You may add multiple documents if you choose. When done, click on “Save & Continue”.

***Note:** If you have an existing contract that has addendums, it is recommended that you include all items as a single document. This also includes letters memorializing a purchasing decision if the contract was signed at a later date.

Manage Contracts – Create Contract

Create Contract

School District 10997 (BEN: 10426) - My Provider - 5 Year Bandwidth/IA Contract - Contract ID #7503

Contract Information Establishing FCC Form 470 Service Provider Contract Dates Pricing Confidentiality Confirmation

Here you will answer additional questions about this contract.

Contract Information

Is this contract based on a State Master Contract? 

YES NO ✓

Is this contract based on a multiple award schedule? 

YES NO ✓

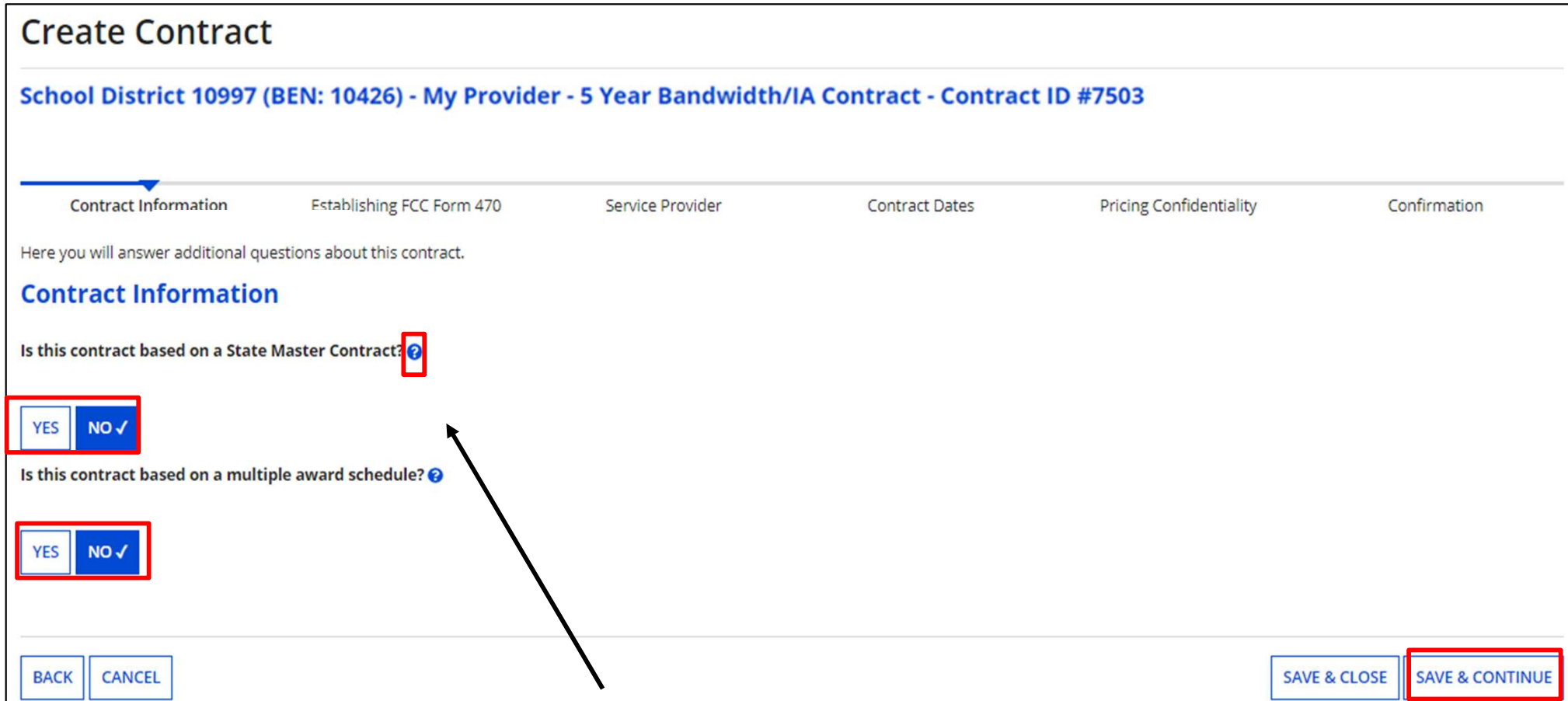

Provide answers. If unsure of the question, hover over “?” for an explanation. Click on “Save & Continue”.

Manage Contracts – Create Contract

Create Contract

School District 400156 (BEN: 17364) - Bandwidth Contract FY2025 - FY2025 - Contract ID #9398

Last Saved: 1/18/2025 11:33 AM EST

Contract Information Establishing FCC Form 470 Service Provider Contract Dates Pricing Confidentiality Confirmation

Here you will answer additional questions about this contract.

Contract Information

Can other applicants piggy back off this contract? [?](#)

YES NO ✓

Was this contract originally created by another applicant, and you then piggy backed off their contract? [?](#)

YES NO ✓

Select the contract Piggy Back options. (The second question doesn't appear until you answer the 1st one.) Click on "Save & Continue".

Manage Contracts – Create Contract

Enter the number of bids received.

Choose “Yes” if a Form 470 was filed and indicate if it was done prior to FY2016.

If you are using FY2016 – FY2025 Form 470, you can search the portal for it. If you are not searching by BEN, enter your search criteria and click on “Search.” The results will be listed below.

Check the box to select, and click on “Save & Continue”

Note: “Allowable Contract Date” is shown. If you choose a 470 that’s before the allowable date, you will receive an error message

Establishing FCC Form 470

Was an FCC Form 470 posted for the product and/or services you are requesting?

YES ✓ NO

How many bids were received? ⓘ*

Enter the number of bids that you received for this product or service.

Was your FCC Form 470 posted prior to Funding Year 2016?

YES NO ✓

Use the search tool below to find the establishing FCC Form 470.

Remember that the services in the contract had to be posted on the FCC Form 470.

Remember you cannot file your Form 471 before the Allowable Contract Date.

Search FCC Forms 470

Search by FCC Form 470 Number

Search by Nickname (Partial or Full)

Search by BEN

<input type="checkbox"/>	FCC Form 470 Number	Nickname	Funding Year ↓	BEN	BEN Name	Allowable Contract Date	Service Type
<input checked="" type="checkbox"/>	250000121	FY2025 XYZ School District - C1 & C2 - LG	2025	17364	School District 400156	11/25/2024	Basic Maintenance of Internal Connections; Data Transmission and/or Internet Access; Internal Connections; Managed Internal Broadband Services

Manage Contracts – Create Contract

Create Contract

School District 400156 (BEN: 17364) - Bandwidth Contract FY2025 - FY2025 - Contract ID #9398

Last Saved: 1/18/2025 11:33 AM EST

Contract Information Establishing FCC Form 470 **Service Provider** Contract Dates Pricing Confidentiality Confirmation

Here you will associate the service provider listed on the contract.

Service Provider

Account Number (e.g., billed telephone number)

If your service provider has given you one or more Account Numbers, please enter them.

Please select the service provider for this contract using the search below.

Search Service Providers

Search by SPIN Search by Name (Full or Partial)

<input checked="" type="checkbox"/>	SPIN	Name	Doing Business As	State
<input checked="" type="checkbox"/>	14010001	USAC Service Provider Organization 1		VA

Enter Account Number if known, but not required

Enter search criteria for Service Provider by SPIN or name, click on "Search".

Check box to select, click on "Save & Continue"

Manage Contracts – Create Contract

Create Contract

School District 400156 (BEN: 17364) - Bandwidth Contract FY2025 - FY2025 - Contract ID #9398

Last Saved: 1/18/2025 11:33 AM EST

Contract Information Establishing FCC Form 470 Service Provider **Contract Dates** Pricing Confidentiality Confirmation

Here you will answer additional questions about the dates on your contract.

Contract Dates

Is this a multi-year contract?

YES ✓ NO

What is the date you awarded your contract?*

01/15/2025

The Contract Expiration Date will be entered in each FRN where you cite this contract.

BACK CANCEL SAVE & CLOSE **SAVE & CONTINUE**

Indicate if this is a multi-year contract and enter the date the contract was awarded, **the date someone from your organization signed it, not the provider’s signature date.**

****Remember, the date must be on or after the Allowable Contract Date listed on the Form 470. The Contract Expiration Date will be entered later in the FRN on the Form 471.**

Manage Contracts – Create Contract

Create Contract

School District 400156 (BEN: 17364) - Bandwidth Contract FY2025 - FY2025 - Contract ID #9398

Last Saved: 1/18/2025 11:33 AM EST

Contract Information Establishing FCC Form 470 Service Provider **Contract Dates** Pricing Confidentiality Confirmation

Here you will answer additional questions about voluntary extensions on your contract

Contract Dates

Does this contract include voluntary extensions?

YES ✓ NO

What is the contract expiration date if all extensions are exercised? *

06/30/2032 

How many extensions are left on the contract? *

2

Enter the number of voluntary extensions that you could still exercise on this contract.

What is the total remaining length of the contract if you exercised all extensions (in months)? *

84

Enter the number of months that would remain in the contract if you exercised all voluntary extensions.

Indicate if voluntary extensions are allowed. If so, provide the contract expiration date if all extensions are exercised, the number of extensions left on the contract, and the total remaining length of the contract if you exercise all extensions.

Note: If your contract states that at the end of the contract term, it will auto-renew until you cancel it, that is not a voluntary extension. It must have a future expiration date.

Click on “Save & Continue”.

Manage Contracts – Create Contract

Create Contract

School District 400156 (BEN: 17364) - Bandwidth Contract FY2025 - FY2025 - Contract ID #9398

Last Saved: 1/18/2025 11:33 AM EST

Contract Information Establishing FCC Form 470 Service Provider Contract Dates **Pricing Confidentiality** Confirmation

Here you will answer additional questions about applicable publication restrictions on this contract.

Pricing Confidentiality

Is there a statute, rule, or other restriction which prohibits publication of the specific pricing information for this contract?

YES NO ✓

BACK CANCEL SAVE & CLOSE **SAVE & CONTINUE**

Indicate if there is a restriction prohibiting publication of the pricing for this contract. If “Yes”, you must state the type of restriction (State Law, Local Rule, Court Order, Contract with Restrictive Terms), and upload Restriction Document.

Click on “Save & Continue”.

Manage Contracts – Create Contract (Confirmation)

Contract Information	Establishing FCC Form 470	Service Provider	Contract Dates	Pricing Confidentiality	Confirmation
Please review the information and submit the information below to complete this contract.					
Contract Information					
Nickname	Bandwidth Contract FY2025 - FY2025		Contract ID	9398	
Can Other Applicants Piggy Back Off This Contract?	No		Contract Number		
Piggy Backed Off Another Contract?	No		Based on a State Master Contract?	No	
			Based on a Multiple Award Schedule?	No	
Establishing FCC Form 470					
Establishing FCC Form 470	#250000121		Number of Bids Received	3	
Service Provider					
Service Provider	USAC Service Provider Organization 1 (SPIN: 14010001)		Account Number		
Contract Dates					
Award Date	1/15/2025		Multi-Year Contract?	Yes	
Includes Voluntary Extensions?	Yes				
Extension Details:					
<ul style="list-style-type: none">• There are 2 remaining voluntary extensions.• There are 84 months remaining in this contract if all extensions are exercised.• This contract expires on 6/30/2032 if all extensions are exercised.					
Pricing Confidentiality					
There is no rule, statute, or other restriction which prohibits publication of the specific pricing information for this contract.					
Supporting Documents					
There are no supporting documents for this contract.					
<input type="button" value="BACK"/>		<input type="button" value="CANCEL"/>		<input type="button" value="SAVE & CLOSE"/>	
				<input type="button" value="COMPLETE"/>	

If an error is found, click on “Back” and correct it.

If the information is correct, click on “Complete”. Keep in mind that if a mistake is found after it’s submitted, you can not edit it. You will have to create a new contract record.

Manage Contracts

Manage Contracts

Contracts - School District 400156 (BEN: 17364)

Use the dropdown to select the type of contract you would like to edit or remove. Click the Add a New Contract button at any time to create a new contract for your organization.

Contract Type Submitted Contracts

Submitted Contracts
The grid below contains all submitted contracts for this organization.

<input type="checkbox"/>	Contract ID	Contract Number	Contract Nickname	Award Date
<input type="checkbox"/>	9398		Bandwidth Contract FY2025 - FY2025	1/15/2025

[CLOSE](#) [ADD A NEW CONTRACT](#) [EDIT](#) [DELETE](#)

To see contracts you've added, go back to "Manage Contracts" as before. Click on the pull-down and choose "Submitted Contracts".

If you started adding a contract but had to "Save & Close" before completing it, click on "Manage Contracts", and choose "My Contract Drafts" as the contract type. Select the contract from the grid and click on "Edit" to continue.

Remember, you will need to complete the steps for each contracted service.

Creating the Form 471

Creating the Form 471

My Applicant Landing Page

Training
Universal Service Administrative Co.

Welcome, School District 10997!

Pending Inquiries

Type: -- Select a Type --
Application/Request: -- Enter an Application/Request ID or Nickname --
Funding Year: -- Select a Funding Year --

APPLY FILTERS CLEAR FILTERS

Pending COMAD Inquiries are not included.

Application/Request Number	Type	Nickname	Inquiry Name	Outreach Type	Date Sent	Due Date	↑	Extn.	Status
No items available									

Notifications

Notification Type: Please select a value
Funding Year: -- Select a Funding Year --

Status: All
 Generated
 Not Generated

Notification	Description	Issued Date	Generated By	Generated On
--------------	-------------	-------------	--------------	--------------

From the Landing Page, click on “FCC Form 471”.

Note: When you begin the FCC Form 471, the basic information about your Billed Entity will be automatically populated from your profile. If you did not update your entity profiles by the Jan. 9th deadline, your FY2024 data will be displayed.

School District 10997 (BEN: 10426) - Cat 1 Bandwidth/IA

Last Saved:

[Basic Information](#) [Entity Information](#) [Funding Requests](#) [Certify](#)

Where applicable, we've completed this section of the form based on information from your applicant entity's profile. If any of the non-editable information is incorrect, or you wish to change the information, please update your profile first by going to your entity record, and clicking Manage Organization from the Related Actions menu. If you do not have access to Manage Organization, please contact your applicant entity's account administrator or create a customer service case to request updates to your applicant entity's profile.

[> FCC Notice Required By The Paperwork Reduction Act \(OMB Control Number: 3060-0806\)](#)

Billed Entity Information

School District 10997	Billed Entity Number: 10426
1 Main Street	FCC Registration Number: 0123456789
Rockville, MD 20850	Applicant Type: School District
012-345-6789	
school_dist_10997@mailinator.com	

Application Nickname

Please enter an application nickname here. ?*

[FCC Form 471 Help](#)

[Show Help](#)

[DISCARD FORM](#) [SAVE & CONTINUE](#)

Enter an application nickname and click on “Save & Continue”.

As before, breadcrumbs are listed at the top, and required fields are indicated by *.

You also have the option to “Discard Form” to discard your work. Once you confirm that you want to discard the form, it will no longer be available in the EPC system.

Continuing a Form 471

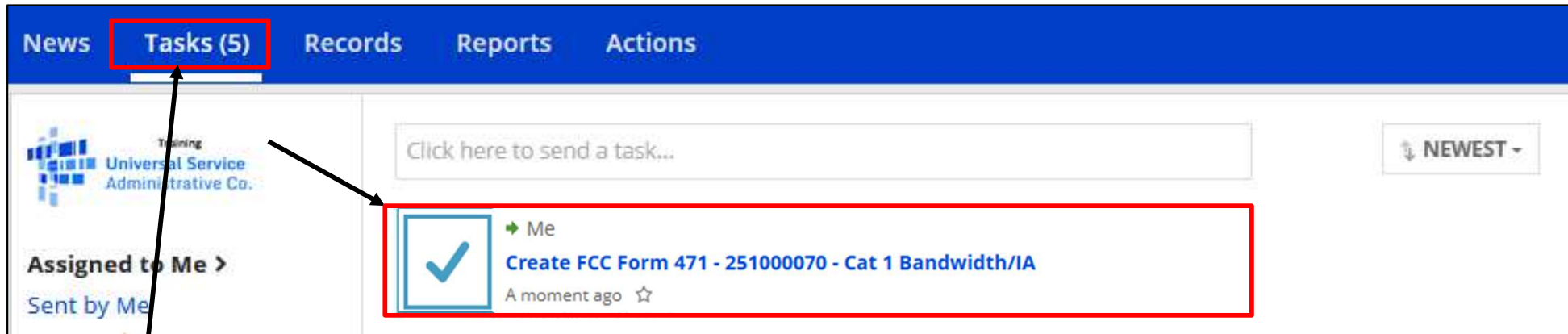

If, after completing part of the form, you need to stop and return to it later:

- Click the **“Task”** tab to locate the in-process form when you return to EPC.

Please note: the task is named “Create Form 471” instead of “Continue”. However, you will be taken to the screen in the application where you left off.

Choose “Yes” if you are the main contact, and your information will be displayed.

Provide “Holiday / Summer” contact information if appropriate, and click on “Save & Continue”

Basic Information Entity Information Funding Requests Certify

Next, you will identify the individuals assisting in seeking E-rate support.

Consultant Information

Consulting Firms
The consulting firms associated with your organization are listed below.

Name	Consultant Registration Number	Phone Number	Email
Consulting Firm 10001	5334	012-345-6789	consulting_firm_10001@mailinator.com

Contact Information

Are you the main contact person?

YES NO

FirstName LastName
sd_user_1_10997@testmail.usac.org
123-456-7890

Holiday / Summer Contact Information

During the month of July please contact me at jane.doe@school.oh.us.gov or 740-555-1212

Please provide any alternate contact information to use during holiday/ vacation period including the name of any alternate contact person and how best to reach them.

FCC Form 471 Help

Show Help

Contact Information

Are you the main contact person?

YES NO

Main Contact Person *

Please select a main contact person by typing the contact person's name or email address.

Note: If you are not the main contact, select “No” and search by name or email address. The person must have an EPC account for this organization & accepted the Terms & Conditions to be added.

Choosing Category of Service

School District 10997 (BEN: 10426) - Cat 1 Bandwidth/IA

Last Saved:

Basic Information

Entity Information

Funding Requests

Certify

Next, you will identify the category of service for the product and services you are requesting. If you need help determining the correct category of service, please review the Eligible Services List on the USAC website.

Category of Service

What is the category of service for the product and services that you are requesting?

You can only select one Category of Service per FCC Form 471. You can submit a second application for the other Category of Service.

CATEGORY 1

- Data Transmission and/or Internet Access

[FCC Form 471 Help](#)

[Show Help](#)

OFF-PREMISES CATEGORY 1

***NEW**

- Wireless School Bus Services and Equipment
- Wi-Fi Hotspots Services and Equipment

CATEGORY 2

- Basic Maintenance of Internal Connections
- Internal Connections
- Managed Internal Broadband Services

BACK

DISCARD FORM

SAVE & CONTINUE

Choose the “Category of Service” for the products/services you’re applying for **this** Form 471. **You must now select:**

- **Category 1** (bandwidth/IA, which includes hotspots for **Bookmobile/Kiosk Access**),
- **OFF-PREMISES CATEGORY 1 (School Bus Wi-Fi and/or Wi-Fi Hotspots for students or library patrons)**
- **Category 2**

You **cannot** select all three on the same Form 471. Also, once you click “Save & Continue”, you **cannot** change the selected category for this application.

Entity Information

Basic Information **Entity Information** Funding Requests Certify

We've completed this section of the form based on information from your applicant entity's profile. If any of the non-editable information is incorrect, or you wish to change the information, please update your profile first by going to your entity record, and clicking Manage Organization from the Related Actions menu. If you do not have access to Manage Organization, please contact your applicant entity's account administrator or create a customer service case to request updates to your applicant entity's profile.

BEN Name	BEN	Urban or Rural	State LEA ID	State School ID	NCES Code	School District Attributes	How does the district report its student count for Category Two budget?	Sum of Student Counts of all Schools in the District	Endowment Amount
School District 10997	10426	Rural	N/A	N/A		Public School District	A number for each school in the district	1431	None

FCC Form 471 Help
[Show Help](#)

[BACK](#) [DISCARD FORM](#) [SAVE & SHARE](#) [SAVE & CONTINUE](#)

This portion of the form populates, and displays information based on your entity's profile. Click on "Save & Continue"

Related Entity Information

School District 10997 (BEN: 10426) - Cat 1 Bandwidth/IA

Last Saved:

Basic Information

Entity Information

Funding Requests

Certify

We've completed this section of the form based on information from your applicant entity's profile. If any of the non-editable information is incorrect, or you wish to change the information, please update your profile first by going to your entity record, and clicking Manage Organization from the Related Actions menu. If you do not have access to Manage Organization, please contact your applicant entity's account administrator or create a customer service case to request updates to your applicant entity's profile.

Related Entity(ies) Information

Entity Details

Fields with '*' next to them are not sortable

Entity Name ↑	Entity Number	Urban or Rural	NIF*	State LEA ID	State School ID	NCES Code	# of students that attend this school full time	Student Count Based on Estimate*	Alternative Discount	CEP Percentage	CEP Base Year	Total Students for C2 Budget	School Attributes*	Endowment Amount	Annexes*
School 1 In District 10997	6913	Rural					512	N/A	None	N/A	N/A	512	Public School	None	View Annexes
School 2 In District 10997	6911	Rural					374	N/A	None	N/A	N/A	374	Public School	None	View Annexes
School 3 In District 10997	6912	Rural					420	N/A	None	N/A	N/A	420	Public School	None	View Annexes

Annexes are buildings that are physically separated from an entity but that are part of that same entity, for example, a second building across the street from the main building that houses additional classrooms or library spaces.

Annex Name School 1 Annex
HIDE ANNEXES
FCC Form 471 Help Show Help
BACK DISCARD FORM SAVE & CONTINUE

View "Related Entity Information". If you are an independent school, you will see the message "No Related Entities". To verify if an annex is associated with a school, click on "View Annexes". If so, it will show below.

Click on "Save & Continue"

Requested Discount Calculation

Basic Information **Entity Information** Funding Requests Certify

We've completed this section of the form based on information from your applicant entity's profile. If any of the non-editable information is incorrect, or you wish to change the information, please update your profile first by going to your entity record, and clicking Manage Organization from the Related Actions menu. If you do not have access to Manage Organization, please contact your applicant entity's account administrator or create a customer service case to request updates to your applicant entity's profile.

Requested Discount Calculation

More than 50 percent of your individual schools must be rural for the school district to be considered rural. (Swing spaces are not considered.)

This discount rate has not been approved for the current year

School District Full-time Enrollment	School District NSLP Count	School District NSLP Percent	School District Urban/Rural Status	Category One Discount Rate	Category Two Discount Rate
1398	1120	80%	Rural	90%	85%

[SHOW ENTITIES](#)

[FCC Form 471 Help](#)
[Show Help](#)

[BACK](#) [DISCARD FORM](#)

Entity Details

Organization	BEN	Total Number Of Students Enrolled In School	Total Number Of Students in School Eligible For NSLP
School District 18 School A	172	430	360
School District 18 School B	173	630	365

[SAVE & CONTINUE](#)

Discount Calculation shown based on your entity's profile. To see a list of all entities, click on "Show Entities". When done, click on "Save & Continue" to start adding funding requests.

If you click on the name of the school, you will be taken out to the Form 471 to the school's summary page. To return to the 471, click on "Tasks", and "Create Form 471" as we saw earlier.

New Contract Funding Requests – Part 1

Basic Information Entity Information **Funding Requests** Certify

This page displays all of the funding requests for this application. From here you can create a new FRN, or edit, delete, or manage the line items of an existing one.

Funding Requests

To create or update specific FRN Line Item(s), please click on the FRN number hyperlink.

<input type="checkbox"/>	FRN	↓ Nickname	Number of FRN Line Items	FRN Calculation
You haven't created any Funding Requests (FRNs) yet. Click the "Add FRN" button to start creating your first FRN				

ADD FRN EDIT FRN REMOVE FRN MANAGE FRN LINE ITEMS

FCC Form 471 Help
Show Help

BACK DISCARD FORM SAVE & SHARE REVIEW FCC FORM 471

Click on “Add FRN” to begin.

Note: “Part 1” is where we indicate how we’re purchasing and associate a contract if appropriate. “Part 2” is where we provide bandwidth info, the connection type, cost, and who’s using the service.

New Contract Funding Requests – Part 1

Basic Information Entity Information **Funding Requests** Certify

On this page, you will select a nickname and the service type of the product and services that you are requesting

Funding Request Key Information

Please enter a Funding Request Nickname here [?](#)*

Is this Funding Request a continuation of an FRN from a previous funding year?

YES NO

Copy FRN

If you want to copy an existing Funding Request, select Copy FRN below. Note that if an FCDL has been issued for the FRN, the approved version of the FRN will be copied.

Service Type

What is the service type of the product and services that you are requesting?

[FCC Form 471 Help](#)

[Show Help](#)

Enter a nickname for the FRN.

Choose “No” as this is a new contract.

Do not click on “Copy FRN” this will be covered shortly....

“Data Transmission and/or Internet Access” auto-populates. Click on “Continue.”

New Contract Funding Requests – Part 1

Choose how the services will be purchased and click on “Continue”.

Basic Information Entity Information **Funding Requests** Certify

Next, you will identify the purchasing agreement type for the product and services you are requesting.

FRN Contract

How are the services for this FRN being purchased?

Contract information is stored in your Profile; you can add a new Contract at any time. Details about your Tariff and Month-to-Month services will be entered in your FRN.

CONTRACT ✓ TARIFF MONTH-TO-MONTH

FCC Form 471 Help

Show Help

BACK CANCEL **CONTINUE**

Associate a Contract

Search by Creating Organization BEN

17364

Please note that BEN is a required field and you can use other search fields to narrow down your result.

Search by Contract ID

Search by Nickname (All or Partial)

Search by Contract No.

CLEAR FILTERS **SEARCH**

<input type="checkbox"/>	Contract ID	Contract Number	Nickname	Award Date	Creating Organization BEN
<input checked="" type="checkbox"/>	9398		Bandwidth Contract FY2025 - FY2025	1/15/2025	17364
<input type="checkbox"/>	9413		ABC Hardware - FY2025	1/15/2025	17364

FCC Form 471 Help

BACK CANCEL CONTINUE

If “Contract” was indicated, search for the associated contract that was uploaded previously.

Enter search criteria and click on “Search”. The BEN is the default. Results will be listed in a grid below. Click box to select contract. The summary will display below.

Contract Summary - Bandwidth Contract FY2025

Contract Number		Account Number	
Establishing FCC Form 470	#250000121	Service Provider	USAC Service Provider Organization 1 (SPIN: 14010001)
Award Date	1/15/2025	Includes Voluntary Extensions?	Yes
Expiration Date (All Extensions)	6/30/2032	Remaining Voluntary Extensions	2
		Total Remaining Contract Length	84

Pricing Confidentiality

There is no rule, statute, or other restriction which prohibits publication of the specific pricing information for this contract.

Contract Information (Additional)

What is the service start date? ?*	What is the date your contract expires for the current term of the contract? ?*
07/01/2025	06/30/2030

Enter the date when services will start for this Funding Year

FCC Form 471 Help

Verify the service start date, that's auto-populated. The default is 07/01/2025 for the upcoming funding year.

Enter the date the contract expires for the current term of the contract, not including extensions.

Once completed, click on "Continue"

New Contract Funding Requests – Part 1

School District 10997 (BEN: 10426) - Cat 1 Bandwidth/IA

Last Saved:

Basic Information

Entity Information

Funding Requests

Certify

Next, you will designate whether this FRN includes a Fiber or Wireless Request.

Fiber Request Key Information

Does this FRN include a request for any of the following eligible broadband options?

- **Special construction.** One-time, upfront costs associated with building out leased lit fiber, leased dark fiber, or a self-provisioned network (i.e. special construction charges), or wireless service; and/or
- **Maintenance and operations.** Costs associated with the maintenance and operations for either a leased dark fiber or self-provisioned network; and/or
- **Network equipment.** Costs associated with the purchase of Network Equipment needed to make leased dark fiber or a self-provisioned network functional (e.g., modulating electronics and other equipment).

If any of the above apply, select "Yes" below.

Select "No" if you are only seeking support for the monthly recurring costs for either a leased lit fiber service or a leased dark fiber service (i.e., recurring payments on a dark fiber lease or IRU), or a wireless service.

Notes:

- If you are seeking support for both the Special Construction, Maintenance and Operation, and/or Network Equipment as well as support for recurring costs associated with leased lit fiber, a dark fiber lease/IRU, or a wireless service then you create multiple FRNs. In each case, you will select a different answer to the Yes/No question based the specific services that are included in that FRN.
- If you select "Yes" below, you should create separate FRNs for special construction charges, maintenance and operations (M&O) charges, and Network Equipment charges. If charges for M&O and Network Equipment are bundled pursuant to a single contract for those products/services, you may use the Network Equipment/M&O FRN option.

YES

NO ✓

FCC Form 471 Help

Show Help

BACK

CANCEL

CONTINUE

Indicate whether this FRN includes any of the options listed above.
If not, select "No" and click on "Continue"

New Contract Funding Requests – Part 1

View if you indicate “Yes”

YES NO

Is this FRN supporting new or existing fiber for leased lit fiber, dark fiber, self-provisioned, or new or existing infrastructure for wireless service?

LIT FIBER DARK FIBER SELF-PROVISIONED WIRELESS

Please remember to create a new FRN for the lit fiber service recurring charges. To access the FRN Line Item screen for lit fiber service recurring charges, select “No” when you receive the question, “Does this FRN include a request for dark fiber, a self-provisioned network, special construction costs to deploy new broadband networks, Network Equipment such as modulating electronics and other equipment necessary to make a broadband service functional, or maintenance and operation costs?”

[FCC Form 471 Help](#)

[Show Help](#)

Choose the fiber type and click “Continue”. Note: you will be reminded to create a separate funding request for the recurring service and/or network equipment.

You will indicate distance, total strands, and number of E-Rate eligible strands. You will then complete the steps to provide a description in the narrative and enter the “One-time Cost”.

Next, you will enter Special Construction key information for this Fiber Request.

Special Construction Key Information

Total Project Plant Route Feet*	Total Strands*
<input type="text" value="85000"/>	<input type="text" value="12"/>
Average Cost Per Foot of Outside Plant*	Number of E-rate Eligible Strands*
<input type="text" value="\$1.25"/>	<input type="text" value="12"/>

[FCC Form 471 Help](#)

[Show Help](#)

Funding Request Narrative

School District 10997 (BEN: 10426) - Cat 1 Bandwidth/IA

Last Saved:

Basic Information

Entity Information

Funding Requests

Certify

Narrative

Provide a brief explanation of the products and services that you are requesting, or provide any other relevant information regarding this Funding Request. You should also use this field to describe any updates to your entity data, such as revised student counts, entity relationships, etc. that you were unable to make after the close of the Administrative filing window for profile updates. These changes will be addressed during the application review process.*

We are requesting bandwidth and Internet Access for our four schools and district admin facility
We were unable to update our entity information before the close of the admin window. The correct counts are:
ABC Elem (Entity No. 123456) Student Count 347, CEP% 57.63, ABC Middle School (Entity No. 123467) Student Count 439, CEP% 64.51,
ABC High School (Entity No. 123489) Student Count 512, CEP% 48.49. Our Base Year is 2024.

FCC Form 471 Help

Show Help

BACK CANCEL

SAVE & VIEW FRN(S)

SAVE & ADD/MANAGE FRN LINE ITEMS

Provide a brief description of the products and services you are requesting.
Note: if you did not update entity information in EPC before the close of the admin window, provide it in the Narrative. If you added a new entity that will receive service but is not listed in EPC yet (or it's service for an annex), provide the entity name in the narrative and explain that they will receive service also.

Click on " **SAVE & ADD/MANAGE FRN LINE ITEMS** " to begin "Part 2" entering the **key information for your funding request.**

Adding FRN Line Items – Part 2

School District 400156 (BEN: 17364) - Cat 1 - Form # 251000073

Last Saved: 1/23/2025 11:51 AM EST

Basic Information Entity Information **Funding Requests** Certify

This page displays all of the funding request line items for this FRN. Click on a line item number below to edit the line items and their recipients of service.

FRN Line Items for FRN #2599000063 - Bandwidth & IA

<input type="checkbox"/>	FRN Line Item Number	Function	Type of Product	Quantity	One-time Quantity	Total Eligible FRN Line Item Cost
You haven't created any FRN Line Items yet. Click the 'Add New FRN Line Item' button to start creating your first FRN Line Item.						

ADD NEW FRN LINE ITEM REMOVE FRN LINE ITEM BULK UPLOAD

FCC Form 471 Help
Show Help

BACK DISCARD FORM SAVE & SHARE SAVE & CONTINUE

Click on “Add New FRN Line Item”.

Keep in mind, an FRN may have several line items that make up the total funding request, depending on the products or services you are purchasing.

Basic Information Entity Information **Funding Requests** Certify

Please enter Product and Service Details Information for this Data Transmission and/or Internet Access Line Item

Product and Service Details for new FRN Line Item for FRN #2599000063 - Bandwidth & IA

[Show Help for Taxes and USF Fees](#)

Purpose ?*

- Internet access service that includes a connection from any applicant site directly to the Internet Service Provider
- Data Connection between two or more sites entirely within the applicant's network
- Data connection(s) for an applicant's hub site to an Internet Service Provider or state/regional network where Internet access service is billed separately
- Internet access service with no circuit (data circuit to ISP state/regional network is billed separately)

Function ?*

Fiber

Type of Connection *

Ethernet

[> Funding Request Narrative](#)

CANCEL

SAVE & CONTINUE

Please select a value

- Fiber
- Copper
- Wireless
- Other
- Miscellaneous

Select the “Purpose,” “Functions,” and “Type of Connection.” **Note: You can drill down to the “Narrative” (> Funding Request Narrative) if changes are needed.** Click on “Save & Continue”.

Note: If bandwidth and/or Internet Access are priced separately, you will enter multiple line items. **If you are unsure, contact your Service Provider.**

But First...

Purpose One & Two Explanation

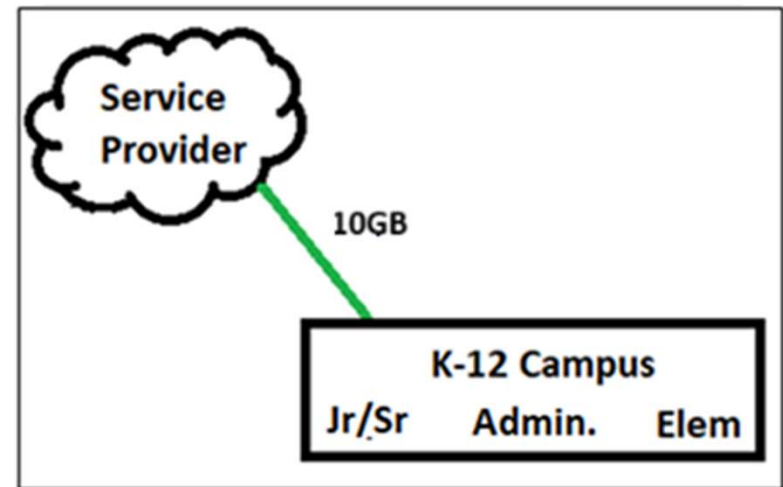
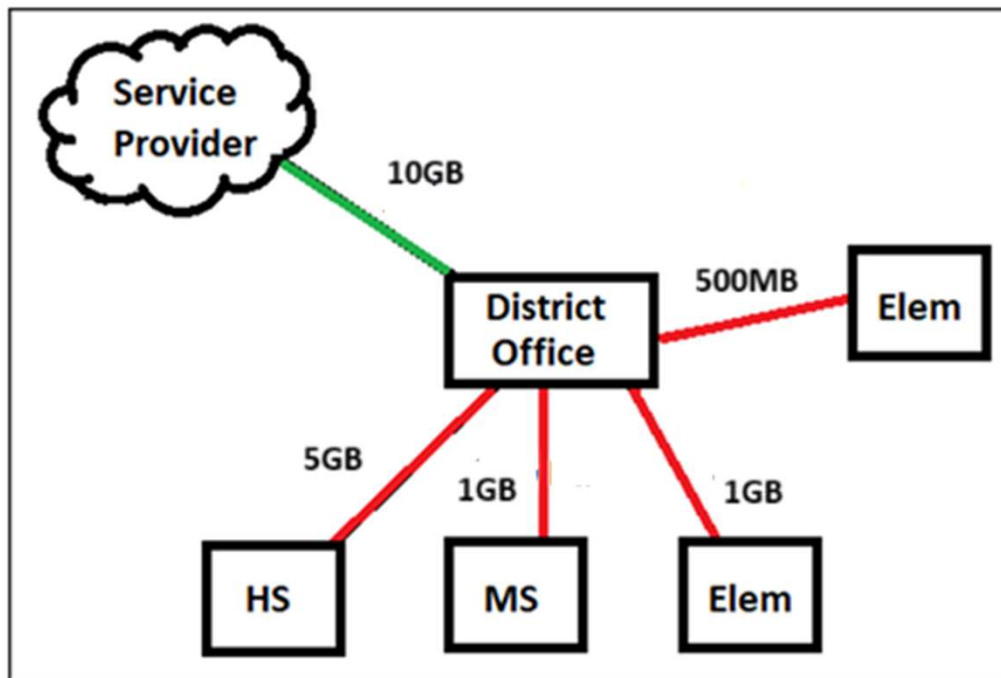

Purpose *

Internet access service that includes a connection from any applicant site directly to the Internet Service Provider

Data Connection between two or more sites entirely within the applicant's network

Data connection(s) for an applicant's hub site to an Internet Service Provider or state/regional network where Internet access service is billed separately

Internet access service with no circuit (data circuit to ISP state/regional network is billed separately)

Note: If the costs are priced separately for the various circuits, you will enter a line item for each, indicating the purpose and bandwidth amount. **If you have multiple circuits BUT your contract just shows one lumpsum cost for all services, choose the 1st purpose.**

If you are unsure, contact your Service Provider.

Purpose Three & Four Explanation

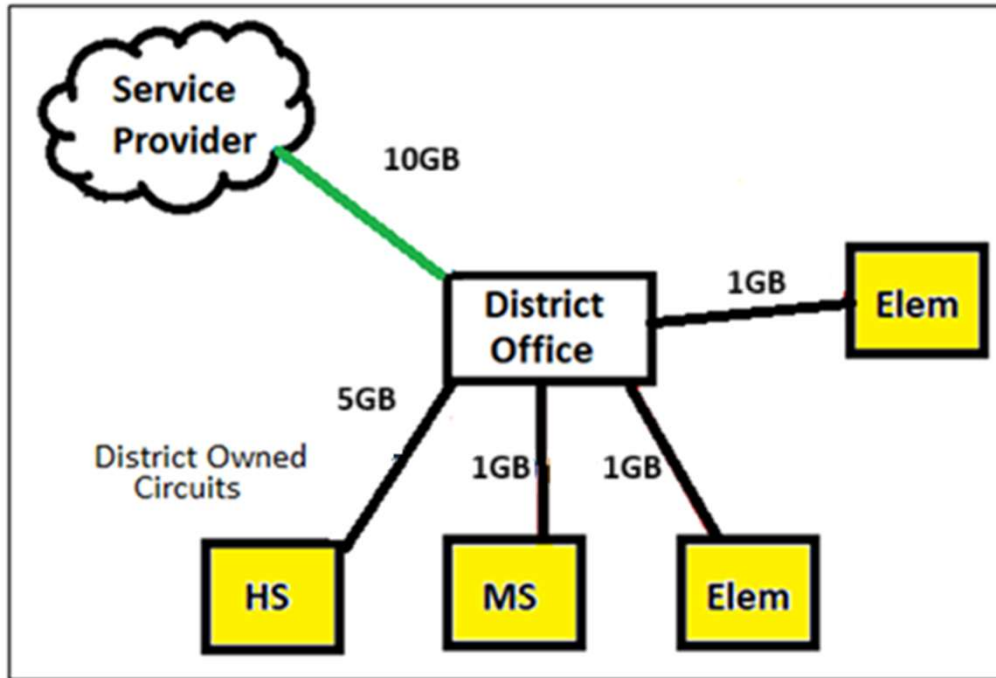

Purpose ?*

- Internet access service that includes a connection from any applicant site directly to the Internet Service Provider
- Data Connection between two or more sites entirely within the applicant's network
- Data connection(s) for an applicant's hub site to an Internet Service Provider or state/regional network where Internet access service is billed separately
- Internet access service with no circuit (data circuit to ISP state/regional network is billed separately)

Example when Internet Access costs are priced separately: If the Internet Access costs are priced separately from the head-in circuit, you will enter a line item indicating the 4th purpose, and then the cost.

If you are unsure, contact your Service Provider.

Product/Service Details – Adding Head-In Circuit, or Lump Sum Service

School District 10997 (BEN: 10426) - FY2024 Cat 1 Bandwidth & IA - Form # 241000028

Last Saved: 1/20/2024 9:48 AM EST

Basic Information Entity Information **Funding Requests** Certify

Please enter Product and Service Details Information for this Data Transmission and/or Internet Access Line Item

Product and Service Details for new FRN Line Item for FRN #2499000029 - FY2024 Cat 1 Bandwidth & IA

Show Help for Taxes and USF Fees

Purpose *

- Internet access service that includes a connection from any applicant site directly to the Internet Service Provider
- Data Connection between two or more sites entirely within the applicant's network
- Data connection(s) for an applicant's hub site to an Internet Service Provider or state/regional network where Internet access service is billed separately
- Internet access service with no circuit (data circuit to ISP state/regional network is billed separately)

Function *

Fiber

Type of Connection *

Ethernet

> Funding Request Narrative

FCC Form 471 Help

Show Help

CANCEL SAVE & CONTINUE

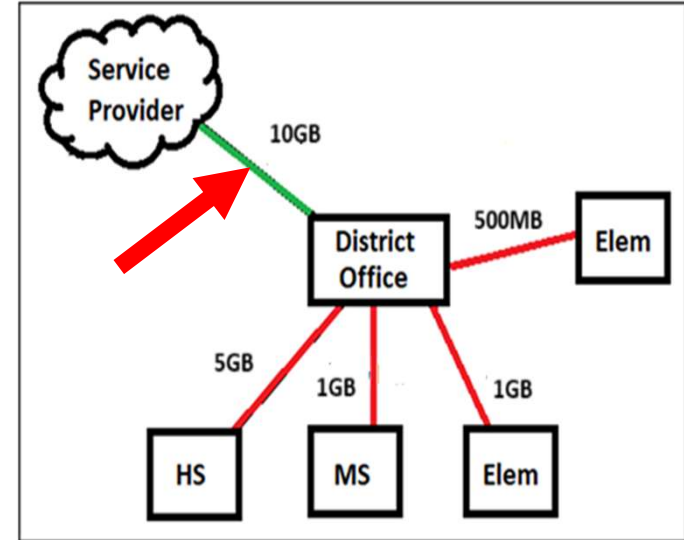

Or

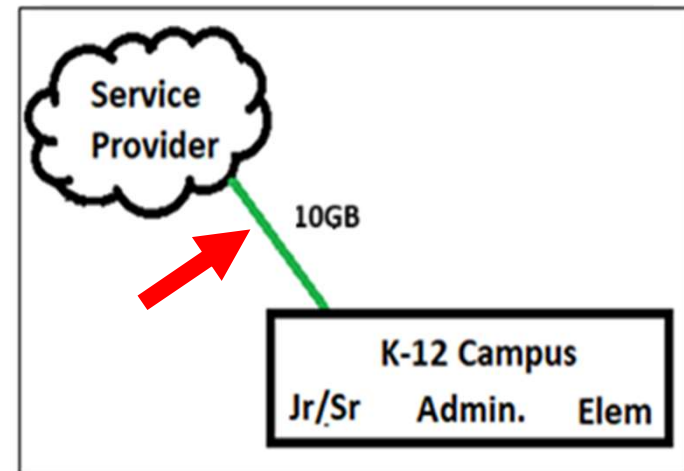

Select the “Purpose,” “Functions,” and “Type of Connection,” then click on “Save & Continue.”

Basic Information Entity Information **Funding Requests** Certify

Please enter Bandwidth Speed Information for this Data Transmission and/or Internet Access Line Item

Bandwidth Speed for new FRN Line Item for FRN #2599000063 - Bandwidth & IA

Bandwidth Download Speed *
10.000

Bandwidth Download Units *
Gbps

Bandwidth Upload Speed *
10.000

Please specify the upload speed if it is different than the download speed.

Bandwidth Upload Units *
Gbps

Burstable Bandwidth?
YES **NO ✓**

FCC Form 471 Help

BACK CANCEL **SAVE & CONTINUE**

Enter Bandwidth Speed Information, indicating if the bandwidth is burstable, then click on "Save & Continue".

Note: Depending on the "Function" and "Type Connection" you chose previously, the bandwidth information may be populated for you.

Again, if you are unsure of the information, contact your Service Provider

Connection Information

School District 10997 (BEN: 10426) - Cat 1 Bandwidth/IA

Last Saved:

Basic Information Entity Information **Funding Requests** Certify

Please enter Connection Information for this Data Transmission and/or Internet Access Line Item

Connection Information for new FRN Line Item for FRN #2599000063 - Bandwidth & IA

Is this a direct connection to a single school, library or a NIF for Internet access? ⓘ*

Does this include firewall services?*

Note: If the request is for direct connections, you will be required to allocate the total number of lines (monthly quantity) among the recipients listed for this line item.

YES ✓ NO

YES ✓ NO

Is this a connection between eligible schools, libraries and NIFs (i.e., a connection that provides a "Wide area network")? ⓘ*

YES NO ✓

FCC Form 471 Help

BACK CANCEL

SAVE & CONTINUE

```
graph TD
    SP1((Service Provider)) --- 10GB --- DO[District Office]
    DO --- 500MB --- Elem1[Elem]
    DO --- 5GB --- HS[HS]
    DO --- 1GB --- MS[MS]
    DO --- 1GB --- Elem2[Elem]
    SP2((Service Provider)) --- 10GB --- KC[K-12 Campus  
Jr/Sr Admin. Elem]
```

Provide Connection Information, and firewall inclusion. When done, click on "Save & Continue".

Note: :You cannot answer "Yes" to both questions displayed in the left-hand column above. If you do, you will receive

You cannot select 'Yes' to both connection questions in the left hand column above.

Cost Calculations

Enter cost information. Fields cannot be left blank, so enter zero if there is no cost.

If the usage of ineligible users (such as Pre-K students) is 10% or less, we no longer need to allocate costs for them!

“Cost” is listed per unit. The “Monthly Quantity” indicates the total number of units, such as the number of circuits.

The “**Months of Service**” is based on the dates you entered under Part 1.”

The table calculates the total costs.

“**One-Time Cost**” would be for installation.

Basic Information Entity Information **Funding Requests** Certify

Please enter Cost Information for this Data Transmission and/or Internet Access Line Item. All fields in the grid below are required. Please enter zero if funds are not requested

Cost Calculation for new FRN Line Item for FRN #2599000063 - Bandwidth & IA

Monthly Cost		One-Time Cost	
Monthly Recurring Unit Cost	\$2,500.00	One-time Unit Cost	\$0.00
Monthly Recurring Unit Ineligible Costs	\$0.00	One-time Ineligible Unit Cost	\$0.00
Monthly Recurring Unit Eligible Costs	= \$2,500.00	One-time Eligible Unit Cost	= \$0.00
Monthly Quantity	1	One-time Quantity	0
Total Monthly Eligible Recurring Costs	= \$2,500.00	Total Eligible One-time Costs	= \$0.00
Months of Service	x 12	Summary	
Total Eligible Recurring Costs	= \$30,000.00	Total Eligible Recurring Costs	\$30,000.00
		Total Eligible One-time Costs	+ \$0.00
		Pre-Discourt Extended Eligible Line Item Cost	= \$30,000.00

[> More Help with the Costs Above](#)
[FCC Form 471 Help](#)
[Show Help](#)

BACK CANCEL **SAVE & CONTINUE**

When completed, click on “Save & Continue”

Manage Recipients of Service – Shared Service

School District 10997 (BEN: 10426) - Cat 1 Bandwidth/IA
Last Saved: -

Basic Information Entity Information **Funding Requests**

Next, you will select Recipients of Service for your Line Item

Manage Recipients of Service

Is every entity for this organization receiving service?

Selected Entities

Please select the organizations you wish to include as recipients of service for this FRN line item and click the Add button.

BEN	BEN Name
6913	School 1 In District 10997
6911	School 2 In District 10997
6912	School 3 In District 10997

FCC Form 471 Help
[Show Help](#)

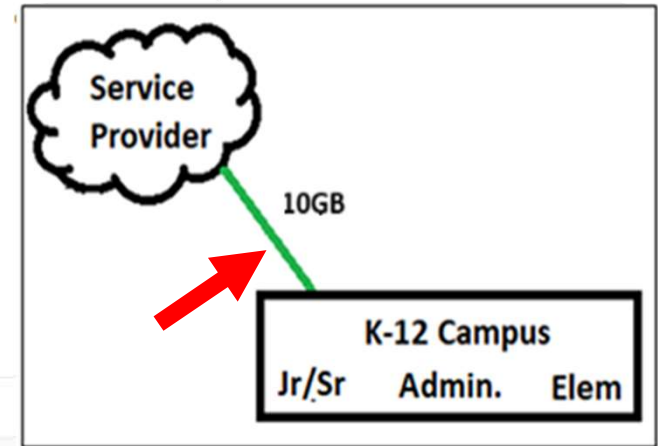

Indicate which entities will receive service for this line item. If all entities will, such as a single circuit serving a K-12 building (or all service costs are lumped together), click on "Yes", then "Save & Continue".

Recipients of Service Review

Basic Information Entity Information **Funding Requests** Certify

Next, you will review the Recipients Of Service selected for this line item. If any updates are needed, please go back to the previous page and update the selected Recipients of Service accordingly.

Recipients of Service for FRN Line Item #2599000063.001

Entity #	Entity Name
18175	School 1 In District 400156
18174	School 2 In District 400156
18176	School 3 In District 400156

[FCC Form 471 Help](#)

Review Recipients of Service. If correct, click on "Save & Continue".

Funding Requests – Part 2

Basic Information Entity Information **Funding Requests** Certify

This page displays all of the funding request line items for this FRN. Click on a line item number below to edit the line items and their recipients of service.

FRN Line Items for FRN #2599000063 - Bandwidth & IA

<input type="checkbox"/>	FRN Line Item Number	↓	Function	Type of Product	Quantity	One-time Quantity	Total Eligible FRN Line Item Cost
<input type="checkbox"/>	2599000063.001		Fiber	Ethernet	1	0	\$30,000.00

ADD NEW FRN LINE ITEM REMOVE FRN LINE ITEM BULK UPLOAD

FCC Form 471 Help
Show Help

BACK DISCARD FORM SAVE & SHARE SAVE & CONTINUE

The grid shows the completed item.

If you need to edit information in the line item, click on the FRN Line-Item Number ([2599000063.001](#)). If done, click on "Save & Continue".

If additional Line Items are needed for this Funding Request, click "Add New FRN Line Item".

Product/Service Details – Adding Circuits Between Buildings

Basic Information Entity Information **Funding Requests** Certify

Please enter Product and Service Details Information for this Data Transmission and/or Internet Access Line Item

Product and Service Details for new FRN Line Item for FRN #2599000063 - Bandwidth & IA

[Show Help for Taxes and USF Fees](#)

Purpose ⓘ *

- Internet access service that includes a connection from any applicant site directly to the Internet Service Provider
- Data Connection between two or more sites entirely within the applicant's network
- Data connection(s) for an applicant's hub site to an Internet Service Provider or state/regional network where Internet access service is billed separately
- Internet access service with no circuit (data circuit to ISP state/regional network is billed separately)

Function ⓘ *

Fiber

Type of Connection *

Ethernet

[> Funding Request Narrative](#)

[FCC Form 471 Help](#)

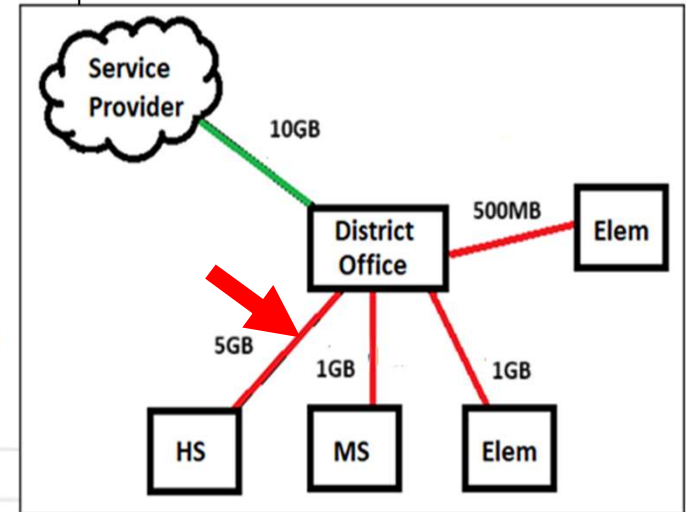

As before, select the “Purpose”, “Functions”, and “Type of Connection” then click on “Save & Continue”.

If different bandwidth amounts are priced separately, you will enter them under separate line items. If you are unsure, contact your Service Provider.

Bandwidth Speeds

Basic Information Entity Information **Funding Requests** Certify

Please enter Bandwidth Speed Information for this Data Transmission and/or Internet Access Line Item

Bandwidth Speed for new FRN Line Item for FRN #2599000063 - Bandwidth & IA

Bandwidth Download Speed * 5.000	Burstable Bandwidth? <input type="button" value="YES"/> <input checked="" type="button" value="NO ✓"/>
Bandwidth Download Units * Gbps	
Bandwidth Upload Speed * 5.000	
Please specify the upload speed if it is different than the download speed.	
Bandwidth Upload Units * Gbps	

FCC Form 471 Help

Enter Bandwidth Speed Information, indicating if the bandwidth is burstable, then click on "Continue".

Again, if you are unsure of the information, contact your Service Provider

Connection Information

Basic Information Entity Information **Funding Requests** Certify

Please enter Connection Information for this Data Transmission and/or Internet Access Line Item

Connection Information for new FRN Line Item for FRN #2599000063 - Bandwidth & IA

Is this a direct connection to a single school, library or a NIF for Internet access? ⓘ*

Does this include firewall services?*

Note: If the request is for direct connections, you will be required to allocate the total number of lines (monthly quantity) among the recipients listed for this line item.

YES NO

Is this a connection between eligible schools, libraries and NIFs (i.e., a connection that provides a "Wide area network")? ⓘ*

YES NO

[FCC Form 471 Help](#)

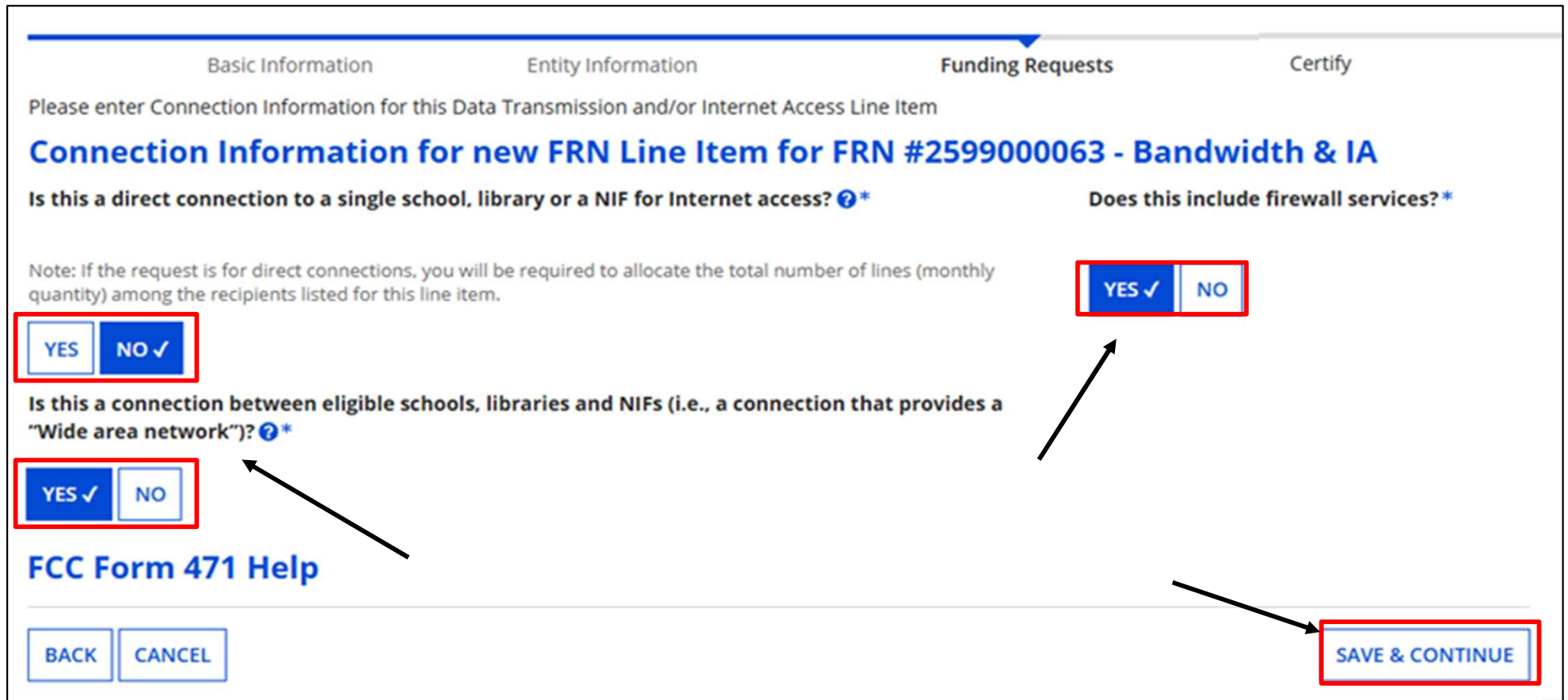

Provide Connection Information, and firewall inclusion. When done, click on "Continue".

This line item is for circuits between buildings, so we answer "No" to the first question, and "Yes" to the second.

Cost Calculations

Basic Information Entity Information **Funding Requests** Certify

Please enter Cost Information for this Data Transmission and/or Internet Access Line Item. All fields in the grid below are required.
Please enter zero if funds are not requested for that field.

Cost Calculation for FRN Line Item #2599000063.002

Monthly Cost		One-Time Cost	
Monthly Recurring Unit Cost	<input type="text" value="\$2,000.00"/>	One-time Unit Cost	<input type="text" value="\$0.00"/>
Monthly Recurring Unit Ineligible Costs	<input type="text" value="\$0.00"/>	One-time Ineligible Unit Cost	<input type="text" value="\$0.00"/>
Monthly Recurring Unit Eligible Costs	= \$2,000.00	One-time Eligible Unit Cost	= \$0.00
Monthly Quantity	<input type="text" value="1"/>	One-time Quantity	<input type="text" value="0"/>
Total Monthly Eligible Recurring Costs	= \$2,000.00	Total Eligible One-time Costs	= \$0.00
Months of Service	x 12	Summary	
Total Eligible Recurring Costs	= \$24,000.00	Total Eligible Recurring Costs	\$24,000.00
> More Help with the Costs Above FCC Form 471 Help		Total Eligible One-time Costs	+ \$0.00
<input type="button" value="BACK"/> <input type="button" value="CANCEL"/>		Pre-Discout Extended Eligible Line Item Cost	= \$24,000.00
		<input type="button" value="SAVE & CONTINUE"/>	

Enter cost information as before. If there is no cost, enter zero.

“Cost” is listed per unit. The “Monthly Quantity” indicates the total number of units included in the service, such as the number of circuits.

When completed, click on “Save & Continue”

Manage Recipients of Service – Direct Connection

Manage Recipients of Service
Is every entity for this organization receiving service?

All Entities

Search by Entity Number (Partial or Full)

Search by Entity Name (Partial or Full)

Please select the organizations you wish to include as recipients of service for this FRN line item and click the Add button.

<input type="checkbox"/>	BEN	BEN Name
<input checked="" type="checkbox"/>	18174	School 2 In District 400156
<input type="checkbox"/>	18175	School 1 In District 400156
<input type="checkbox"/>	18176	School 3 In District 400156

Selected Entities

<input type="checkbox"/>	Entity #	Entity Name
<input checked="" type="checkbox"/>	18174	School 2 In District 400156

FCC Form 471 Help

If “No”, select from your organization’s list of entities, and click on “Add”. Your selection will be shown below. When done, click on “Save & Continue”.

Manage Recipients of Service – Shared Service

Manage Recipients of Service
Is every entity for this organization receiving service?

All Entities

Search by Entity Number (Partial or Full) Search by Entity Name (Partial or Full)

Please select the organizations you wish to include as recipients of service for this FRN line item and click the Add button.

<input type="checkbox"/>	BEN	BEN Name
<input type="checkbox"/>	6913	School 1 In District 10997
<input checked="" type="checkbox"/>	6911	School 2 In District 10997
<input checked="" type="checkbox"/>	6912	School 3 In District 10997

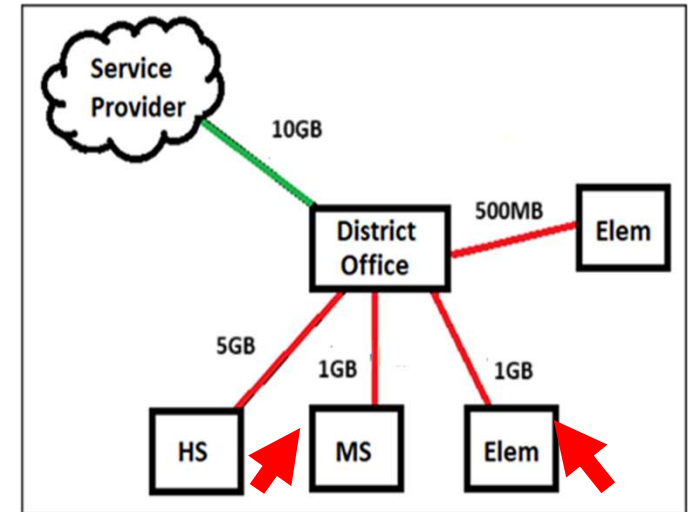

Basic Information Entity Information **Funding Requests** Certify

Next, you will review the Recipients Of Service selected for this line item. If any updates are needed, please go back to the previous page and update the selected Recipients of Service accordingly.

Recipients of Service for FRN Line Item #2599000063.002

Entity #	Entity Name
18175	School 1 In District 400156
18176	School 3 In District 400156

FCC Form 471 Help
[Show Help](#)

Here we indicated that the circuits between buildings will serve the two schools by choosing “No” to all entities and choosing the appropriate buildings. Click on “Save & Continue”.

Adding FRN Line Items

School District 10997 (BEN: 10426) - FY2024 Cat 1 Bandwidth & IA - Form # 241000028
Last Saved: 1/20/2024 11:01 AM EST

Basic Information Entity Information **Funding Requests** Certify

This page displays all of the funding request line items for this FRN. Click on a line item number below to edit the line items and their recipients of service.

FRN Line Items for FRN #2499000029 - FY2024 Cat 1 Bandwidth & IA

<input type="checkbox"/>	FRN Line Item Number	Function	Type of Product	Quantity	One-time Quantity	Total Eligible FRN Line Item Cost
<input type="checkbox"/>	2499000029.002	Fiber	Ethernet	2	0	\$18,000.00
<input type="checkbox"/>	2499000029.001	Fiber	Ethernet	1	0	\$18,000.00

ADD NEW FRN LINE ITEM REMOVE FRN LINE ITEM BULK UPLOAD

FCC Form 471 Help
Show Help

BACK DISCARD FORM SAVE & SHARE **SAVE & CONTINUE**

Continue clicking on “Add New FRN Line Item” to complete FRN or “Save & Continue”.

Adding Internet Access Only

Basic Information Entity Information **Funding Requests** Certify

Please enter Product and Service Details Information for this Data Transmission and/or Internet Access Line Item

Product and Service Details for new FRN Line Item for FRN #2599000063 - Bandwidth & IA

Show Help for Taxes and USF Fees

Purpose ?*

- Internet access service that includes a connection from any applicant site directly to the Internet Service Provider
- Data Connection between two or more sites entirely within the applicant's network
- Data connection(s) for an applicant's hub site to an Internet Service Provider or state/regional network where Internet access service is billed separately
- Internet access service with no circuit (data circuit to ISP state/regional network is billed separately)

Function ?*

Fiber

Type of Connection *

Ethernet

> Funding Request Narrative
FCC Form 471 Help

CANCEL

SAVE & CONTINUE

View when adding “Internet Access service with no circuit” such as when the district owns the circuits between the buildings, **and you have a separate cost on your contract for Internet Access Only.**

Basic Information Entity Information **Funding Requests** Certify

Please enter Bandwidth Speed Information for this Data Transmission and/or Internet Access Line Item

Bandwidth Speed for new FRN Line Item for FRN #2599000063 - Bandwidth & IA

Bandwidth Download Speed *	<input type="text" value="10.000"/>	Burstable Bandwidth? <input type="button" value="YES"/> <input checked="" type="button" value="NO ✓"/>
Bandwidth Download Units *	<input type="text" value="Gbps"/>	
Bandwidth Upload Speed *	<input type="text" value="10.000"/>	
<small>Please specify the upload speed if it is different than the download speed.</small>		
Bandwidth Upload Units *	<input type="text" value="Gbps"/>	

[FCC Form 471 Help](#)

Enter Bandwidth Speed Information, indicating if the bandwidth is burstable as before, then click on "Save & Continue".

Connection Information

School District 10997 (BEN: 10426) - Cat 1 Bandwidth/IA
Last Saved:

Basic Information Entity Information **Funding Requests** Certify

Please enter Connection Information for this Data Transmission and/or Internet Access Line Item

Connection Information for new FRN Line Item for FRN #2599000063 - Bandwidth & IA

Is this a direct connection to a single school, library or a NIF for Internet access? ⓘ*

Does this include firewall services?*

Note: If the request is for direct connections, you will be required to allocate the total number of lines (monthly quantity) among the recipients listed for this line item.

YES NO

YES NO

Is this a connection between eligible schools, libraries and NIFs (i.e., a connection that provides a "Wide area network")? ⓘ*

YES NO

FCC Form 471 Help
Show Help

When indicating Internet Access costs only, we still receive the connection questions. Typically, we answer "Yes" to the first question. When done, click on "Save & Continue".

Cost Calculations

Enter cost information. If there is no cost, enter zero.

Cost Calculation for new FRN Line Item for FRN #2599000063 - Bandwidth & IA

Monthly Cost		One-Time Cost	
Monthly Recurring Unit Cost	\$2,500.00	One-time Unit Cost	\$0.00
Monthly Recurring Unit Ineligible Costs	\$0.00	One-time Ineligible Unit Cost	\$0.00
Monthly Recurring Unit Eligible Costs	= \$2,500.00	One-time Eligible Unit Cost	= \$0.00
Monthly Quantity	1	One-time Quantity	0
Total Monthly Eligible Recurring Costs	= \$2,500.00	Total Eligible One-time Costs	= \$0.00
Months of Service	x 12		
	\$30,000.00		

Summary	
Total Eligible Recurring Costs	\$30,000.00
Total Eligible One-time Costs	+ \$0.00
Pre-Discount Extended Eligible Line Item Cost	= \$30,000.00

SAVE & CONTINUE

Manage Recipients of Service

Is every entity for this organization receiving service?

YES ✓ **NO**

Selected Entities

Please select the organizations you wish to include as recipients of service for this FRN line

BEN	BEN Name
6913	School 1 In District 10997
6911	School 2 In District 10997
6912	School 3 In District 10997

FCC Form 471 Help

Show Help

BACK **CANCEL** **SAVE & CONTINUE**

When completed, click on "Save & Continue" and add Recipients of Service as before.

School District 400156 (BEN: 17364) - Cat 1 - Form # 251000073

Last Saved: 1/23/2025 6:13 PM EST

Basic Information

Entity Information

Funding Requests

Certify

This page displays all of the funding request line items for this FRN. Click on a line item number below to edit the line items and their recipients of service.

FRN Line Items for FRN #2599000063 - Bandwidth & IA

<input type="checkbox"/>	FRN Line Item Number	Function	Type of Product	Quantity	One-time Quantity	Total Eligible FRN Line Item Cost
<input type="checkbox"/>	2599000063.003	Fiber	Ethernet	1	0	\$600,000.00
<input type="checkbox"/>	2599000063.002	Fiber	Ethernet	1	0	\$24,000.00
<input type="checkbox"/>	2599000063.001	Fiber	Ethernet	1	0	\$30,000.00

ADD NEW FRN LINE ITEM

REMOVE FRN LINE ITEM

BULK UPLOAD

FCC Form 471 Help

Show Help

BACK

DISCARD FORM

SAVE & SHARE

SAVE & CONTINUE

We've now added all line items for the funding request. If you need to edit information in the line item, click on the Line Item Number. If done, click on "Save & Continue".

Note: "Save & Share" is used if you want to share with another EPC user in your district.

Funding Requests

School District 400156 (BEN: 17364) - Cat 1 - Form # 251000073

Last Saved: 1/23/2025 6:13 PM EST

Basic Information

Entity Information

Funding Requests

Certify

This page displays all of the funding requests for this application. From here you can create a new FRN, or edit, delete, or manage the line items of an existing one.

Funding Requests

To create or update specific FRN Line Item(s), please click on the FRN number hyperlink.

<input type="checkbox"/>	FRN	Nickname	Number of FRN Line Items	FRN Calculation	
<input type="checkbox"/>	2599000063	Bandwidth & IA	3	\$588,600.00	ADD FRN EDIT FRN REMOVE FRN MANAGE FRN LINE ITEMS

Amount of funding you're requesting

FCC Form 471 Help

Show Help

[BACK](#) [DISCARD FORM](#)

We now see a funding calculation showing the total number of line items it includes. If you need to add another FRN, click "Add FRN". If done, click on "Review FCC Form 471".

[SAVE & SHARE](#) [REVIEW FCC FORM 471](#)

If you need to edit the **Part 1** FRN info (Contract information, Service Start Date or Expiration Date, or Narrative), click the box to the left, and then "[EDIT FRN](#)".

If you need to edit the FRN Line Items (Costs, bandwidth amounts, Recipients of Service), click the box and then "[MANAGE FRN LINE ITEMS](#)" or click on the funding request number and then the line item you need to edit.

Copying FRN

Start by clicking on “Add FRN” as before:

Copy FRN

The “Copy” option can be used when you’re in year 2 or more of a multi-year contract.

Enter Previous Year FRN and click on “Copy FRN”.

Note: if changes were made to the FRN during PIA review, the changes will be copied.

Search by previous Form 471 or FRN number. (Enter the FRN a second time, even though we just provided it)

Select the check box and then click on “Continue.” A pop-up will appear indicating that it may take up to one minute to complete. Click on “Yes.”

Funding Request Key Information

Please enter a Funding Request Nickname here ⓘ *

FY2024 Bandwidth

Is this Funding Request a continuation of an FRN from a previous funding year?

YES NO

Previous Year FRN Number *

2499044283

Copy FRN

If you want to copy an existing Funding Request, select Copy FRN below. Note that if an FCDL has been issued for the FRN, the approved version of the FRN will be copied.

COPY FRN

Search for FRN

Search by FCC Form 471

Search by FRN Number

2499044283

CLEAR FILTERS **SEARCH**

Select an FRN

<input checked="" type="checkbox"/>	FCC Form 471	FRN Number	FRN Nickname	Service Type	Service Provider Name
<input checked="" type="checkbox"/>	241031118	2499044283	Branch Circuits	Data Transmission and/or Internet Access	USAC Service Provider Organization 2

FCC Form 471 Help

Show Help

BACK **CANCEL** **CONTINUE**

Quick Way to Get the Information Needed

Go to: www.E-Ratecentral.com



E-Rate Utilization Summary Chart

FY: [1998](#) | [1999](#) | [2000](#) | [2001](#) | [2002](#) | [2003](#) | [2004](#) | [2005](#) | [2006](#) | [2007](#) | [2008](#) | [2009](#) | [2010](#) | [2011](#) | [2012](#) | [2013](#) | [2014](#) | [2015](#) | [2016](#) | [2017](#) | [2018](#) | [2019](#) | [2020](#) | [2021](#) | [2022](#)

FY	Requested FRNs	Funded FRNs	486 on File	Requested Amount	Committed Category 1	Committed Category 2
2025	0	0	0	\$0.00	\$0.00	\$0.00
2024	5	5	5	\$40,938.39	\$38,585.16	\$1,373.18
2023	4	4	4	\$38,649.75	\$38,649.75	\$0.00
2022	4	4	4	\$56,077.49	\$56,077.49	\$0.00

471	FRN	SPIN	Service Provider	Service *
241031118	2499044282	143050436	Charter Communications Operating, LLC	IA
241031118	2499044283	143000677	Verizon Wireless (Cellco Partnership)	IA

1. Enter your Billed Entity Number.
2. Click on Funding Year
3. See your 471, FRN, and SPIN information.

You must click “Refresh” to complete the copy. It won’t advance on its own.

Library System 10344 (BEN: 1979) - FY2025 Cat 1 Bandwidth - ABC Library - Form # 251000050
Last Saved: 1/18/2025 3:11 PM EST

Basic Information Entity Information **Funding Requests** Certify

FRN is copying and may take up to one minute to complete. Please hit refresh to check if FRN copy is complete.

REFRESH

You will receive the following notification indicating you must enter the Service Start and Service End Dates. Click on “Continue”.

Basic Information Entity Information **Funding Requests** Certifications

FRN has been successfully copied.

Program rules prohibit the funding of duplicate services, which means different funding requests cannot contain services that provide the same functionality to the same population in the same location during the same period of time.

Your FRN has been copied into your current FCC Form 471. As you navigate through the FRN, you must review all of the copied data. Please keep in mind:

- To the extent that the current year form does not have the same fields as the form you are copying, the data will not be copied.
- Copy FRN will not copy Service Start and Service End Dates. When entering these Start and End dates, please ensure that the Recipients of Service and the appropriate cost in the line items are correct if the months of service are different from the original FRN.
- Copy FRN will copy all Recipients of Service. Please make sure that the Recipients of Service associated with each line item are valid for the current Funding Year.
- Copy FRN will not copy the recipient(s) of service cost allocation information. If you are a Consortium or ESA School District, you can update the budgeted entity(ies)'s cost allocation information for line items by clicking the 'Manage FRN Line Items' button available on the Funding Requests screen.

You can now edit the copied FRN, and the corresponding FRN Line Items as required.

CONTINUE

Library System 10344 (BEN: 1979) - FY2025 Cat 1 Bandwidth - ABC Library - Form # 251000050
Last Saved: 1/18/2025 3:11 PM EST

Basic Information Entity Information **Funding Requests** Certify

On this page, you will select a nickname and the service type of the product and services that you are requesting

Funding Request Key Information

Please enter a Funding Request Nickname here *

Is this Funding Request a continuation of an FRN from a previous funding year?

YES NO

Previous Year FRN Number *

Service Type

What is the service type of the product and services that you are requesting? Please delete all line items for this Funding Request if you wish to modify the Service Type

Data Transmission and/or Internet Access

FCC Form 471 Help
Show Help

View after copy is completed. "Service Type" will be indicated. Click on "Continue".

Based on previous FRN info, "Contract" is chosen. Click on "Continue".

Next, you will identify the purchasing agreement type for the product and services you are requesting.

FRN Contract

How are the services for this FRN being purchased?

Contract information is stored in your Profile; you can add a new Contract at any time. Details about your Tariff and Month-to-Month services will be entered in your FRN.

FCC Form 471 Help

Show Help

[SEARCH FOR CONTRACTS](#)

Contract Summary

Contract Number		Account Number	
Establishing FCC Form 470	#210000055	Service Provider	USAC Service Provider Organization 2 (SPIN: 14010002)
Award Date	12/1/2020	Includes Voluntary Extensions?	Yes
Expiration Date (All Extensions)		Remaining Voluntary Extensions	2
		Total Remaining Contract Length	84

Pricing Confidentiality

There is no rule, statute, or other restriction which prohibits publication of the specific pricing information for this contract.

Contract Information (Additional)

What is the service start date? ⓘ*

07/01/2025 📅

Enter the date when services will start for this Funding Year

What is the date your contract expires for the current term of the contract? ⓘ*

06/30/2030 📅

FCC Form 471 Help

Show Help

[BACK](#) [CANCEL](#) [CONTINUE](#)

Verify information that copied from previous FRN. When copying, you must **enter the Service Start and Service End dates**. These fields will be blank, and you'll receive an error message if you do not enter the dates. Remember, the Service Start Date is the first day of the upcoming funding year and cannot be prior to **07/01/2025**. Click on "Continue".

Verify information copied from the previous FRN; click on “Continue”.

Update the narrative if needed, including enrollment and NSLP info.

Click “Save & Add/Manage FRN Line Items” to update costs if needed.

If there is no change, click on “Save & View FRNs”.

Next, you will designate whether this FRN includes a Fiber Request.

Fiber Request Key Information

Does this FRN include a request for any of the following eligible broadband options?

- **Special construction.** One-time, upfront costs associated with building out leased lit fiber, leased dark fiber, or a self-provisioned network (i.e. special construction charges); and/or
- **Maintenance and operations.** Costs associated with the maintenance and operations for either a leased dark fiber or self-provisioned network; and/or
- **Network equipment.** Costs associated with the purchase of Network Equipment needed to make leased dark fiber or a self-provisioned network functional (e.g., modulating electronics and other equipment).

If any of the above apply, select "Yes" below.

Select "No" if you are only seeking support for the monthly recurring costs for either a leased lit fiber service or a leased dark fiber service (i.e., recurring payments on a dark fiber lease or IRU).

Notes:

- If you are seeking support for both the Special Construction, Maintenance and Operation, and/or Network Equipment as well as support for recurring costs associated with leased lit fiber or a dark fiber lease/IRU, then you create multiple FRNs. In each case, you will select a different answer to the Yes/No question based the specific services that are included in that FRN.
- If you select "Yes" below, you should create separate FRNs for special construction charges, maintenance and operations (M&O) charges, and Network Equipment charges. If charges for M&O and Network Equipment are bundled pursuant to a single contract for those products/services, you may use the Network Equipment/M&O FRN option.

YES NO

[FCC Form 471 Help](#)
Show Help

School District 10997 (BEN: 10426) - Cat 1 Bandwidth/IA

Last Saved:

Basic Information Entity Information **Funding Requests** Certify

Narrative

Provide a brief explanation of the products and services that you are requesting, or provide any other relevant information regarding this Funding Request. You should also use this field to describe any updates to your entity data, such as revised student counts, entity relationships, etc, that you were unable to make after the close of the Administrative filing window for profile updates. These changes will be addressed during the application review process.*

Internet Access and Bandwidth request supporting 3 buildings.

Click the "Save & Continue" button to complete this step of the FRN creation process. On the next screen, click on the FRN number that was just created to begin adding FRN Line Items and the associated Recipients of Service. If you wish to start another FRN without adding FRN Line Items, click the "Add FRN" button.

[FCC Form 471 Help](#)
Show Help

“Save & View FRNs” -
If no changes are needed, click on “Review FCC Form 471”.

If you clicked on “Manage FRN Line Item”, click on the line-item number to edit, and update information. Click on “Save & Continue” to return to Funding Requests.

School District 10997 (BEN: 10426) - Cat 1 Bandwidth/IA

Last Saved:

Basic Information Entity Information **Funding Requests** Certify

This page displays all of the funding requests for this application. From here you can create a new FRN, or edit, delete, or manage the line items of an existing one.

Funding Requests

To create or update specific FRN Line Items, please click on the FRN number hyperlink.

FRN	Nickname	Number of FRN Line Items	FRN Calculation
<input type="checkbox"/> 2599000042	FY2025 Bookmobile/Kiosk Hotspots	1	\$863.78
<input type="checkbox"/> 2599000041	FY2025 Bandwidth	1	\$16,200.00

ADD FRN EDIT FRN REMOVE FRN MANAGE FRN LINE ITEMS

FCC Form 471 Help

Show Help

BACK DISCARD FORM SAVE & SHARE **REVIEW FCC FORM 471**

School District 10997 (BEN: 10426) - Cat 1 Bandwidth/IA

Last Saved:

Basic Information Entity Information **Funding Requests** Certify

This page displays all of the funding request line items for this FRN. Click on a line item number below to edit the line items and their recipients of service.

FRN Line Items for FRN #2599000041 - FY2025 Bandwidth

FRN Line Item Number	Function	Type of Product	Quantity	One-time Quantity	Total Eligible FRN Line Item Cost
<input type="checkbox"/> 2599000041.001	Fiber	Ethernet	3	0	\$18,000.00

ADD NEW FRN LINE ITEM REMOVE FRN LINE ITEM BULK UPLOAD

FCC Form 471 Help

Show Help

BACK DISCARD FORM SAVE & SHARE **SAVE & CONTINUE**

Off-Premises Category 1 Form 471

Off-Premises Category 1 Form 471

School District 400156 (BEN: 17364) - Bus Wi-Fi - Form # 251000083

Last Saved: 1/23/2025 6:30 PM EST

Basic Information

Entity Information

Funding Requests

Certify

Next, you will identify the category of service for the product and services you are requesting. If you need help determining the correct category of service, please review the Eligible Services List on the USAC website.

Category of Service

What is the category of service for the product and services that you are requesting?

You can only select one Category of Service per FCC Form 471. You can submit a second application for the other Category of Service.

CATEGORY 1

- Data Transmission and/or Internet Access

OFF-PREMISES CATEGORY 1 ✓

- Wireless School Bus Services and Equipment
- Wi-Fi Hotspots Services and Equipment

CATEGORY 2

- Basic Maintenance of Internal Connections
- Internal Connections
- Managed Internal Broadband Services

FCC Form 471 Help

Show Help

BACK

DISCARD FORM

SAVE & CONTINUE

Follow previous steps to start a Form 471. At “Category of Service,” click on “Off-Premises Category 1” and “Save & Continue.”

Off-Premises Category 1 Form 471

Library System 10344 (BEN: 1979) - FY2025 Cat 1 Patron Hotspots - ABC Library - Form # 251000051

Last Saved: 1/18/2025 3:57 PM EST

Basic Information

Entity Information

Funding Requests

Certify

We've completed this section of the form based on information from your applicant entity's profile. If any of the non-editable information is incorrect, or you wish to change the information, please update your profile first by going to your entity record, and clicking Manage Organization from the Related Actions menu. If you do not have access to Manage Organization, please contact your applicant entity's account administrator or create a customer service case to request updates to your applicant entity's profile.

Entity Information

Related Entity(ies) Information

Library systems derive their discount rate in part based on the student count from the school district in which the main branch is located. Fields with "*" next to them are not sortable.

Name	Entity Number	FSCS Code*	Urban/ Rural Status*	NIF*	Total square footage of library outlet*	Is this the main branch?*	School District in which the main branch is located*	School District Number in which the main branch is located*	Library Attributes*	Annexes*
Library 1 In System 10344	3313		Rural	No	1000	Yes	School District For	19272	Public Library, Main	View

FCC Form 471

Show Help

BACK

DISCARD

Requested Discount Calculation

More than 50 percent of your library outlets/branches must be rural for the library system to be considered rural.

This discount rate has not been approved for the current year

Associated School District Full-time Enrollment	Associated School District NSLP Count	Associated School District NSLP Percentage	Library System Urban/Rural Status	Category One Discount Rate	Category Two Discount Rate
100	100	100%	Rural	90%	85%

SHOW ADDITIONAL INFORMATION

FCC Form 471 Help

Show Help

BACK

DISCARD FORM

SAVE & CONTINUE

You will see the Related Entities and Requested Discount Calculation. Click on "Save & Continue" for each.

Off-Premises Category 1 Form 471

School District 400156 (BEN: 17364) - Bus Wi-Fi - Form # 251000083

Last Saved: 1/23/2025 6:32 PM EST

Basic Information

Entity Information

Funding Requests

Certify

This page displays all of the funding requests for this application. From here you can create a new FRN, or edit, delete, or manage the line items of an existing one.

Funding Requests

To create or update specific FRN Line Item(s), please click on the FRN number hyperlink.

<input type="checkbox"/>	FRN	↓ Nickname	Number of FRN Line Items	FRN Calculation
You haven't created any Funding Requests (FRNs) yet. Click the "Add FRN" button to start creating your first FRN				

ADD FRN

EDIT FRN

REMOVE FRN

MANAGE FRN LINE ITEMS

Click on "Add FRN" to begin.

Funding Requests – Part 1

Basic Information Entity Information **Funding Requests** Certify

On this page, you will select a nickname and the service type of the product and services that you are requesting

Funding Request Key Information

Please enter a Funding Request Nickname here [?](#) *

 ← Enter a nickname for the FRN.

Is this Funding Request a continuation of an FRN from a previous funding year? *

Choose “No” as this is a new contract.

Copy FRN

If you want to copy an existing Funding Request, select Copy FRN below. Note that if an FCDL has been issued for the FRN, the approved version of the FRN will be copied.

Do not click on “Copy FRN”

Service Type

What is the service type of the product and services that you are requesting?

 ←

FCC Form 471 Help

- Wi-Fi Hotspots Services and Equipment
- Wireless School Bus Services and Equipment

Under “Service Type” you will see the option for Wi-Fi Hotspots or Wireless School Bus. Select “ Wireless School Bus Services and Equipment .” Click on “Continue.”

Funding Requests – Part 1

Choose how the services will be purchased and click on “Continue”.

School District 400156 (BEN: 17364) - Bus Wi-Fi - Form # 251000083
Last Saved: 1/23/2025 6:32 PM EST

Basic Information Entity Information **Funding Requests** Certify

Next, you will identify the purchasing agreement type for the product and services you are requesting.

FRN Contract
How are the services for this FRN being purchased?
Contract information is stored in your Profile; you can add a new Contract at any time. Details about your Tariff and Month-to-Month services will be entered in your FRN.

CONTRACT TARIFF MONTH-TO-MONTH

FCC Form 471 Help
Show Help

Associate a Contract

Search by Creating Organization BEN:

Search by Nickname (All or Partial):

Please note that BEN is a required field and you can use other search fields to narrow down your result.

Search by Contract ID:

Search by Contract No.:

<input type="checkbox"/>	Contract ID	Contract Number	Nickname	Award Date	Creating Organization BEN
<input checked="" type="checkbox"/>	7505		My Provider - 5 Year Bandwidth Contract	1/15/2025	1979

FCC Form 471 Help
Show Help

If “Contract” was indicated, search for the associated contract that was uploaded previously.

Enter search criteria and click on “Search”. Results will be listed in a grid below. Click box to select contract. The summary will display below.

Pricing Confidentiality
There is no rule, statute, or other restriction which prohibits publication of the specific pricing information for this contract.

Contract Information (Additional)

What is the service start date? ?*
07/01/2025

What is the date your contract expires for the current term of the contract? ?*
06/30/2028

Enter the date when services will start for this Funding Year

FCC Form 471 Help
Show Help

[BACK](#) [CANCEL](#) [CONTINUE](#)

Verify the service start date; that's auto-populated. The default is 07/01/2025 for the upcoming funding year.

Enter the date the contract expires for the current term of the contract, not including extensions.

Once completed, click on "Continue"

Funding Request Narrative

Library System 10344 (BEN: 1979) - FY2025 Cat 1 Patron Hotspots - ABC Library - Form # 251000051

Last Saved: 1/18/2025 3:57 PM EST

Basic Information

Entity Information

Funding Requests

Certify

Narrative

Provide a brief explanation of the products and services that you are requesting, or provide any other relevant information regarding this Funding Request. You should also use this field to describe any updates to your entity data, such as revised student counts, entity relationships, etc. that you were unable to make after the close of the Administrative filing window for profile updates. These changes will be addressed during the application review process. *

We are seeking Wi-Fi service and equipment to serve our bus fleet of 15 buses.
We were unable to update our entity information before the close of the admin window. The correct counts are:
ABC Elem (Entity No. 123456) Student Count 347, CEP% 57.63, ABC Middle School (Entity No. 123467) Student Count 439, CEP% 64.51,
ABC High School (Entity No. 123489) Student Count 512, CEP% 48.49. Our Base Year is 2024.

FCC Form 471 Help

Show Help

BACK

CANCEL

SAVE & VIEW FRN(S)

SAVE & ADD/MANAGE FRN LINE ITEMS

Provide a brief description of the products and services you are requesting. Click on " **SAVE & ADD/MANAGE FRN LINE ITEMS** " to begin "Part 2" entering the **key information for your funding request.**

Adding FRN Line Items

Basic Information Entity Information **Funding Requests** Certify

This page displays all of the funding request line items for this FRN. Click on a line item number below to edit the line items and their recipients of service.

FRN Line Items for FRN #2599000075 - Bus Wi-Fi

<input type="checkbox"/>	FRN Line Item Number	↓ Function	Type of Product	Quantity	One-time Quantity	Total Eligible FRN Line Item Cost
You haven't created any FRN Line Items yet. Click the 'Add New FRN Line Item' button to start creating your first FRN Line Item.						

ADD NEW FRN LINE ITEM REMOVE FRN LINE ITEM

FCC Form 471 Help
Show Help

BACK DISCARD FORM SAVE & SHARE **SAVE & CONTINUE**

Click on “Add New FRN Line Item.”

Remember that if you are requesting hotspot service, equipment, and taxes, if indicated, you will need to add multiple FRN line items.

Product/Service Details

School District 400156 (BEN: 17364) - Bus Wi-Fi - Form # 251000083

Last Saved: 1/23/2025 6:51 PM EST

Basic Information

Entity Information

Funding Requests

Certify

Please enter Product and Service Details Information for this Wireless School Bus Services and Equipment Line Item

Product and Service Details for new FRN Line Item for FRN #2599000075 - Bus Wi-Fi

Purpose

Internet access service that includes a connection from any applicant site directly to the Internet Service Provider

Function

Wireless

Type of Connection *

Wireless Internet services that can be delivered to a school bus

Number of Buses Being Serviced *

15

Wireless Internet services that can be delivered to a school bus
Bus Wi-Fi Equipment
Installation
Taxes and USF fees
Other Reasonable Fees

[> Funding Request Narrative](#)

[FCC Form 471 Help](#)

CANCEL

SAVE & CONTINUE

“Purpose” and “Functions” are auto-populated. Select “Type of Connection,” and enter the number of buses being served. Click on “Save & Continue.”

School District 400156 (BEN: 17364) - Bus Wi-Fi - Form # 251000083
Last Saved: 1/23/2025 6:51 PM EST

Basic Information Entity Information **Funding Requests** Certify

Please enter Cost Information for this Wireless School Bus Services and Equipment Line Item. All fields in the grid below are required. Please enter zero if funds are available.

Cost Calculation for new FRN Line Item for FRN #2599000075 - Bus Wi-Fi

Monthly Cost		One-Time Cost	
Monthly Recurring Unit Cost	\$40.00	One-time Unit Cost	\$0.00
Monthly Recurring Unit Ineligible Costs	\$0.00	One-time Ineligible Unit Cost	\$0.00
Monthly Recurring Unit Eligible Costs	= \$40.00	One-time Eligible Unit Cost	= \$0.00
Monthly Quantity	15	One-time Quantity	0
Total Monthly Eligible Recurring Costs	= \$600.00	Total Eligible One-time Costs	= \$0.00
Months of Service	x 12		
Total Eligible Recurring Costs	= \$7,200.00		

[> More Help with the Costs Above](#)
[FCC Form 471 Help](#)

BACK CANCEL **SAVE & CONTINUE**

Enter monthly recurring cost information on the left-hand side of the screen. Fields cannot be left blank. If there is no cost, enter zero. When completed, click on "Save & Continue."

Manage Recipients of Service – Shared Service

Manage Recipients of Service

Is every entity for this organization receiving service?

YES ✓ NO

Selected Entities

Please select the organizations you wish to include as recipients of service for this FRN line item and click the Add button.

BEN	BEN Name
6913	School 1 In District 10997
6911	School 2 In District 10997
6912	School 3 In District 10997

FCC Form 471 Help
[Show Help](#)

Indicate all entities by clicking on "Yes." When done, click on "Save & Continue." You'll see the recipients selected.

Click on "Save & Continue" again.

Adding FRN Line Items

School District 400156 (BEN: 17364) - Bus Wi-Fi - Form # 251000083

Last Saved: 1/23/2025 7:10 PM EST

Basic Information Entity Information **Funding Requests** Certify

This page displays all of the funding request line items for this FRN. Click on a line item number below to edit the line items and their recipients of service.

FRN Line Items for FRN #2599000075 - Bus Wi-Fi

<input type="checkbox"/>	FRN Line Item Number	Function	Type of Product	Quantity	One-time Quantity	Total Eligible FRN Line Item Cost
<input type="checkbox"/>	2599000075.001	Wireless	Wireless Internet services that can be delivered to a school bus	15	0	\$7,200.00

ADD NEW FRN LINE ITEM REMOVE FRN LINE ITEM

FCC Form 471 Help
Show Help

BACK DISCARD FORM SAVE & SHARE SAVE & CONTINUE

The grid shows the completed item. **If you need to edit information in the line item**, click on the FRN Line-Item Number.

If additional Line Items are needed for this Funding Request, click “Add New FRN Line Item”. If done, click on “Save & Continue”.

Product/Service Details – Adding Devices

Product and Service Details for new FRN Line Item for FRN #2599000075 - Bus Wi-Fi

Purpose

Internet access service that includes a connection from any applicant site directly to the Internet Service Provider

Function

Wireless

Type of Connection*

Bus Wi-Fi Equipment

Number of Buses Being Serviced *

15

Select “Bus Wi-Fi Equipment” under “Type of Connection,” and how many buses. Click on “Save & Continue.”

Please enter Cost Information for this Wireless School Bus Services and Equipment Line Item. All fields in the grid below are required. Please enter zero

Cost Calculation for new FRN Line Item for FRN #2599000075 - Bus Wi-Fi

Monthly Cost		One-Time Cost	
Monthly Recurring Unit Cost	\$0.00	One-time Unit Cost	\$500.00
Monthly Recurring Unit Ineligible Costs	\$0.00	One-time Ineligible Unit Cost	\$0.00
Monthly Recurring Unit Eligible Costs	= \$0.00	One-time Eligible Unit Cost	= \$500.00
Monthly Quantity	0	One-time Quantity	15
Total Monthly Eligible Recurring Costs	= \$0.00	Total Eligible One-time Costs	= \$7,500.00
Months of Service	x 12		
Total Eligible Recurring Costs	= \$0.00		
Summary			
Total Eligible Recurring Costs			\$0.00
Total Eligible One-time Costs			+ \$7,500.00
Pre-Discussion Extended Eligible Line Item Cost			= \$7,500.00

Enter one-time equipment cost information on the right-hand side of the screen. Enter zeros under Monthly Cost on the left. When completed, click “Save & Continue” and select Recipients of Service.

Adding FRN Line Items

School District 400156 (BEN: 17364) - Bus Wi-Fi - Form # 251000083

Last Saved: 1/23/2025 7:16 PM EST

Basic Information Entity Information **Funding Requests** Certify

This page displays all of the funding request line items for this FRN. Click on a line item number below to edit the line items and their recipients of service.

FRN Line Items for FRN #2599000075 - Bus Wi-Fi

<input type="checkbox"/>	FRN Line Item Number	Function	Type of Product	Quantity	One-time Quantity	Total Eligible FRN Line Item Cost
<input type="checkbox"/>	2599000075.002	Wireless	Bus Wi-Fi Equipment	0	15	\$7,500.00
<input type="checkbox"/>	2599000075.001	Wireless	Wireless Internet services that can be delivered to a school bus	15	0	\$7,200.00

ADD NEW FRN LINE ITEM REMOVE FRN LINE ITEM

FCC Form 471 Help
Show Help

BACK **DISCARD FORM** **SAVE & SHARE** **SAVE & CONTINUE**

Continue adding line items if needed. If adding Taxes and USF Fees, use the Monthly Cost portion of the screen as before. If there is an installation fee per bus equipment, enter the cost under One-Time Cost. When done, click on “Save & Continue.”

Completing the Form 471

Completing the Form 471

School District 400156 (BEN: 17364) - Cat 1 - Form # 251000073
Last Saved: 1/23/2025 6:13 PM EST

Basic Information Entity Information **Funding Requests** Certify

This page displays all of the funding requests for this application. From here you can create a new FRN, or edit, delete, or manage the line items of an existing one.

Funding Requests

To create or update specific FRN Line Item(s), please click on the FRN number hyperlink.

<input type="checkbox"/>	FRN	Nickname	Number of FRN Line Items	FRN Calculation
<input type="checkbox"/>	2599000063	Bandwidth & IA	3	\$588,600.00

ADD FRN **EDIT FRN** **REMOVE FRN** **MANAGE FRN LINE ITEMS**

FCC Form 471 Help

Show Help

BACK **DISCARD FORM** **SAVE & SHARE** **REVIEW FCC FORM 471**

School District 10997 (BEN: 10426) - Cat 1 Bandwidth/IA
Last Saved:

Basic Information Entity Information **Funding Requests** Certify

FCC Form 471 Draft version of the PDF generation is in progress and it may take a few minutes to complete. Please click 'Refresh' once or twice a minute to check if the PDF generation is complete. If you don't want to wait, click 'Resume Task Later' to close the current screen, and EPC will assign you a task to continue PDF review and certification process.

RESUME TASK LATER **REFRESH**

To complete/submit your Form 471, click on “Review FCC Form 471” and “Yes” to the popup. Instead of being taken out of the Form 471 like we see with the Form 470, you must click on “**REFRESH**” to receive the draft version of the form and it. Be patient, it may take a little while to display.

You can click on “**RESUME TASK LATER**” if you prefer to complete at a later time.

FCC Form 471 - Funding Year 2025

School District 400156 (BEN: 17364) - Cat 1 - Form # 251000073

Last Saved: 1/23/2025 6:13 PM EST

Basic Information Entity Information Funding Requests **Certify**

Please download and carefully review this FCC Form 471 before certifying.

Download Document Link
USAC_FCC_FORM_471_APPLICATION_251000050_DRAFT

By checking this box, I certify that the information in the PDF document above is correct.

FCC Form 471 Help
Show Help

EDIT FORM SEND FOR CERTIFICATION **CONTINUE TO CERTIFICATION**

If you chose the “ **REFRESH** ” option, click on the draft document to view the PDF. If necessary, click on “Edit Form” to make corrections.

Click the box just below the document to certify if correct. You can then click on “Continue to Certification” or “Send for Certification” to complete the application.

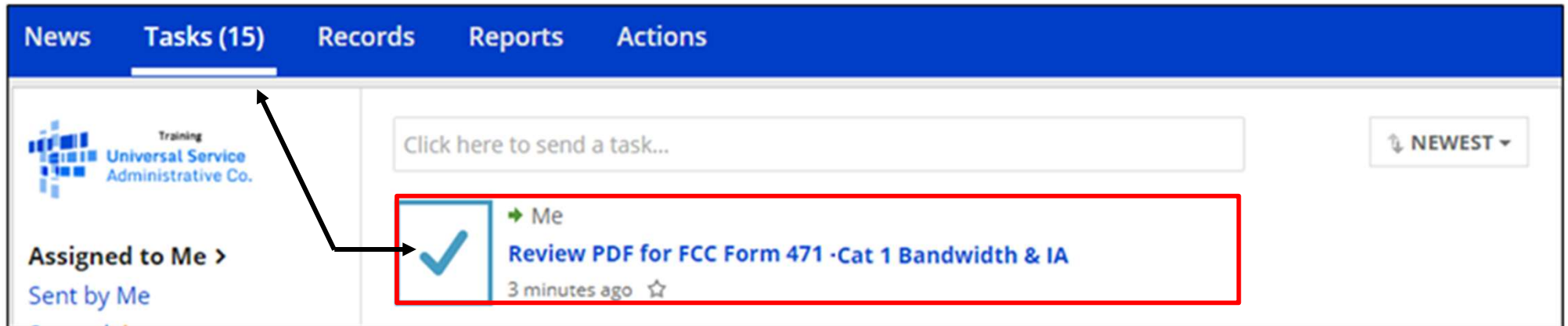

If you clicked on “ [RESUME TASK LATER](#) “, click on “Tasks” on the blue menu bar to find the newly created task.

Click on the “Review PDF for FCC Form 471” to continue.

Certifying the Form 471

Certify FCC Form 471

School District 400156 (BEN: 17364) - Cat 1 - Form # 251000073

Last Saved: 1/23/2025 6:13 PM EST

Basic Information

Entity Information

Funding Requests

Certify

Please complete the certifications below.

Applicant Certifications

- certify that the entities listed in this application are eligible for support because they are schools under the statutory definitions of elementary and secondary schools found in the No Child Left Behind Act of 2001, 20 U.S.C. §§ 7801(18) and (38), that do not operate as for-profit businesses and do not have endowments exceeding \$50 million.
- certify that the entity I represent or the entities listed on this application have secured access, separately or through this program, to all of the resources, including computers, training, software, internal connections, maintenance, and electrical capacity, necessary to use the services purchased effectively. I recognize that some of the aforementioned resources are not eligible for support. I certify that the entities I represent or the entities listed on this application have secured access to all of the resources to pay the discounted charges for eligible services from funds to which access has been secured in the current funding year. I certify that the Billed Entity will pay the non-discount portion of the cost of the goods and services to the service provider(s).

Total Funding Summary

Below is a summary of the total line item costs on this FCC Form 471:

Summary	
Total funding year pre-discount eligible amount on this FCC Form 471	\$66,000.00
Total funding commitment request amount on this FCC Form 471	\$59,400.00
Total applicant non-discount share of the eligible amount	\$6,600.00
Total budgeted amount allocated to resources not eligible for E-rate support	\$75,000.00
Total amount necessary for the applicant to pay the non-discount share of eligible and any ineligible amounts	\$81,600.00
Are you receiving any of the funds directly from a service provider listed on any of the FCC Forms 471 filed by this Billed Entity for this funding year?	No
Has a service provider listed on any of the FCC Forms 471 filed by this Billed Entity for this funding year assisted you in locating funds needed to pay your non-discounted share?	No

After reading the certifications, check the boxes.

Enter your budget amount.

Click on the pull-downs to answer the “gotcha” questions. Be very careful!! Remember, it’s a program violation if you receive funds from your service provider!!

Just say no!!

Certifying the Form 471

- certify an FCC Form 470 was posted and that any related RFP was made available for at least 28 days before considering all bids received and selecting a service provider. I certify that all bids submitted were carefully considered and the most cost-effective service offering was selected, with price being the primary factor considered, and is the most cost-effective means of meeting educational needs and technology goals.
- certify that the entity responsible for selecting the service provider(s) has reviewed all applicable FCC, state, and local procurement/competitive bidding requirements and that the entity or entities listed on this application have complied with them.
- certify that the services the applicant purchases at discounts provided by 47 U.S.C. § 254 will be used primarily for educational purposes, see 47 C.F.R. § 54.500 and will not be sold, resold or transferred in consideration or money or any other thing of value, except as permitted by the Commission's rules at 47 C.F.R. § 54.513. Additionally, I certify that the entity or entities listed on this application have not received anything of value or a promise of anything of value, as prohibited by the Commission's rules at 47 C.F.R. § 54.503(d), other than services and equipment sought by means of this form, from the service provider, or any representative or agent hereof or any consultant in connection with this request for services.
- certify that I and the entity(ies) I represent have complied with all program rules and I acknowledge that failure to do so may result in denial of discount funding and/or cancellation of funding commitments. There are signed contracts or other legally binding agreements covering all of the services listed on this FCC Form 471 except for those services provided under non-contracted tariffed or month-to-month arrangements. I acknowledge that failure to comply with program rules could result in civil or criminal prosecution by the appropriate law enforcement authorities.
- acknowledge that the discount level used for shared services is conditional, for future years, upon ensuring that the most disadvantaged schools and libraries that are treated as sharing in the service, receive an appropriate share of benefits from those services.
- certify that I will retain required documents for a period of at least 10 years (or whatever retention period is required by the rules in effect at the time of this certification) after the later of the last day of the applicable funding year or the service delivery deadline for the associated funding request. I acknowledge that I may be audited pursuant to participation in the schools and libraries program. I certify that I will retain all documents necessary to demonstrate compliance with the statute and Commission records available to USAC.
- certify that I am authorized to order telecommunications and other support services on behalf of the entity(ies) listed on this application, that I have examined this request, that the entity(ies) listed on this application have complied with the terms, conditions and purposes of the Communications Act, 47 U.S.C. §§ 502, 503(b), or fine or imprisonment under the Communications Act.
- acknowledge that FCC rules provide that persons who have been convicted of a crime involving fraud or dishonesty, or any person associated in any way with my entity and/or the schools and libraries support mechanism.
- certify that if any of the Funding Requests on this FCC Form 471 are for shared services, I have allocated the eligible and ineligible components as required by the Commission's rules at 47 C.F.R. § 54.504.
- certify that the non-discount portion of the costs for eligible services will not be paid by the service provider. The pre-discount costs of eligible services featured on this FCC Form 471 are net of any rebates or discounts offered by the service provider. I acknowledge that, for the purpose of this rule, the provision, by the provider of a supported service, of free services or products unrelated to the supported service or product will be considered a rebate of some or all of the cost of the supported services.

False statements on this form may result in civil liability and/or criminal prosecution. To electronically sign and certify this form, click "Yes" below. To affirm that you (1) understand the statements above and (2) represent the entity featured, and have the authority to make the certifications, on this form, click "Yes" below.

[FCC Form 471 Help](#)

[Show Help](#)

Continue checking all boxes.

When done, click on "Certify", and then "Yes" in the pop-up.

You will receive confirmation that the form was certified.

Certification Confirmation

School District 400156 (BEN: 17364) - Cat 1 - Form # 251000073

Last Saved: 1/23/2025 6:13 PM EST

Basic Information Entity Information Funding Requests **Certify**

You have successfully filed FCC Form 471 #251000050 for FY 2025

Certification Date

1/18/2025 3:53 PM EST

Authorized Person

Name FirstName LastName
Title Training
Employer Library System 10344
Address Address1
Rockville, MD 20850
Phone 111-222-3333
Email ls_user_10344@mailinator.com

Please click here to access your certified FCC Form 471 PDF

FCC Form 471 Help

Show Help

CLOSE

Click the link to access a PDF copy of your certified Form 471.
Click on “Close” when done.

After the Form 471 – Next Steps

Finding Your 471 & Making Corrections

To find a submitted Form 471, scroll down to the bottom of the Landing Page, select 471 as “Type” and 2025 for “Funding Year”.

Click on the Application Number.

▼ FCC Forms and Post-Commitment Requests

FCC Forms Status All
 Post-Commitment Requests Incomplete
 Certified
 Committed

Form Type:

Funding Year:

Application Number	Nickname	Funding Year	Status	Certified Date
251000050	FY2025 Cat 1 Bandwidth - ABC Library	2025	Certified	1/18/2025 3:53 PM EST
251000051	FY2025 Cat 1 Patron Hotspots - ABC Library	2025	Certified	1/18/2025 5:29 PM EST

Records / FCC Forms 471

FY2025 Cat 1 Bandwidth - ABC Library - #251000050

Summary Funding Requests Review Inquiries Deferral History Discount Calculation Entity Information News **Related Actions**

- Respond to Inquiries**
Answer Reviewer Questions.
- Submit Modification Request (RAL)**
Submit a RAL Modification Request for this Application

Form 471 Modification Request

Would you like to request changes to an entity or this application?

[> RAL Request Help](#)

To make corrections after your Form 471 has been certified, submit a RAL Modification Request. For details on how to submit, see “Submitting Form 471 RAL Corrections” on my website for a step-by-step guide covering various scenarios at <https://www.ohio-k12.help/erate/e-rate-resources/> .

Application Review - PIA

Program Integrity Assurance (PIA) will review your application after it is submitted and communicate with you through EPC.

To look for Review Inquires, search for 471 as before:

The screenshot shows the 'FCC Forms and Post-Commitment Requests' section. The 'Form Type' is set to 'FCC Form 471' and the 'Funding Year' is '2025'. A table lists applications with columns for Application Number, Nickname, and Funding Year. The application with ID 251000050 is highlighted. A red box highlights the 'Review Inquiries' link in the application details, and another red box highlights the 'Respond to Inquiries' link in the actions menu.

Application Number	Nickname	Funding Year
251000050	FY2025 Cat 1 Bandwidth - ABC Library	2025
251000051	FY2025 Cat 1 Patron Hotspots - ABC Library	2025

Records / FCC Forms 471

FY2025 Cat 1 Bandwidth - #251000050

Summary Funding Requests **Review Inquiries** Deferral History Discount Calculation Entity Information News **Related Actions**

- Respond to Inquiries**
Answer Reviewer Questions.
- Submit Modification Request (RAL)**
Submit a RAL Modification Request for this Application

Click on “Review Inquires” or “Related Actions” and then “Respond to Inquires”.

Application Review - PIA

- Reviewers
 - verify the eligibility of the schools and libraries and their discount levels.
 - verify that the services requested are eligible for E-Rate discounts.
 - communicate with you with requests for additional documentation.
 - may ask for additional verification of your compliance with program rules.
- You are given an opportunity to make allowable corrections to your form.

Application Review - PIA

- Have documentation ready
- Respond to inquiries and provide information promptly, by the deadline (usually 15 days)
- Ask for clarification if you are unsure what is needed
- Ask early for an extension if you need it
- Put responses in writing
- Document all responses

Funding Decision

The Funding Commitment Decision Letter (FCDL) is a letter issued by USAC to both the applicant and the service provider that contains decisions on their funding requests. You'll receive an email when it is issued. The letter states which funding requests of the Form 471 are approved or denied.

Applicants and service providers should carefully review their FCDL for details on approved or denied requests and any adjustments made to the original requests, as well as next steps (such as the deadline for filing an appeal which is 60 days for the date of the FCDL).

Change Options To Be Aware Of

[Funding Request Report](#) | [FCC Form 470](#) | [FCC Form 471](#) | [FCC Form 486](#) | [Appeal](#) | [IDD Extension](#) | [FCC Form 500](#) | [SPIN Change](#) | [Service Substitution](#) | [Manage Users](#) | [Manage Organizations](#) | [EPC E-Rate Invoicing](#) | [USAC Website](#) | [Contact Us](#) | [Help](#)

SPIN Changes

- If you enter the wrong SPIN, the company merges with another, or your chosen vendor can't provide the service.

Service Substitutions

- If you entered incorrect service information, or you are making an allowed change to the service, use this to notify USAC of the change.

FCC Form 500 - Use this form if you need to do the following:

- Change service start date
- Change contract expiration date
- Cancel funding request
- Reduce funding request
- Submit service delivery extension request (non-recurring)



Questions?!!

Contact Information

E-Rate Support and Information

Lorrie Germann:

lgermann@ohiocsc.org or

lorrie.germann@education.ohio.gov

www.ohio-k12.help/erate

Call: 740-253-1153

